

# MICRO SERIES

## Water Temperature Control Unit



## Technical Specifications

For production applications requiring exact temperature control in limited spaces, nothing measures up to Micro Series Water Temperature Control Units from Sterling. Micro Series Water Temperature Control Units have an operating leaving water temperature range of 32°F up to a maximum of 250°F (0°C to 121°C).

Each Micro Series TCU delivers huge performance in a compact package. Available with heater configurations in 3kW, 6kW or 9kW, these units provide consistent and reliable heating - just the kind of innovation you expect from the leader in temperature control.

## Features

### Standard Features

- 1/16 DIN microprocessor based PID controller
- Non-ferrous construction
- Easily removable panels for quick access to internal components
- Incoloy™ immersion heater with IEC contactors
- Pressure switch set at 150 psig
- NEMA 1 electrical enclosure
- 250°F (121°C) maximum operating temperature
- Motor Circuit Protector
- Independent high temperature safety thermostat
- 3/4" on all connections
- 1/2 - 3/4 hp process pumps with silicone carbide seals
- Automatic vent sequence
- 1 year parts and labor warranty at the factory
- 3 year controller warranty

### Optional Features

- Casters; available in lieu of rubber feet
- Manual bypass
- Pressure regulator/relief valve for water supply (shipped loose)
- Y-Strainer (shipped loose)
- Quick cool switch
- Auto system water purge (mold purge), shipped loose
- General fault audible/visual alarm
- Remote Start/stop
- Communications – RS232, RS485, RS485-SPI
- Ten-foot power cord; no plug, shipped loose
- Rotary, thru-the-door disconnect switch
- UL/cUL-listed electrical subpanel
- Operating voltages: 208/3/60, 230/3/60, 400/3/50, 575/3/60
- Pressure gauges (Shipped loose, to be mounted on back of unit)

## Product Diagrams

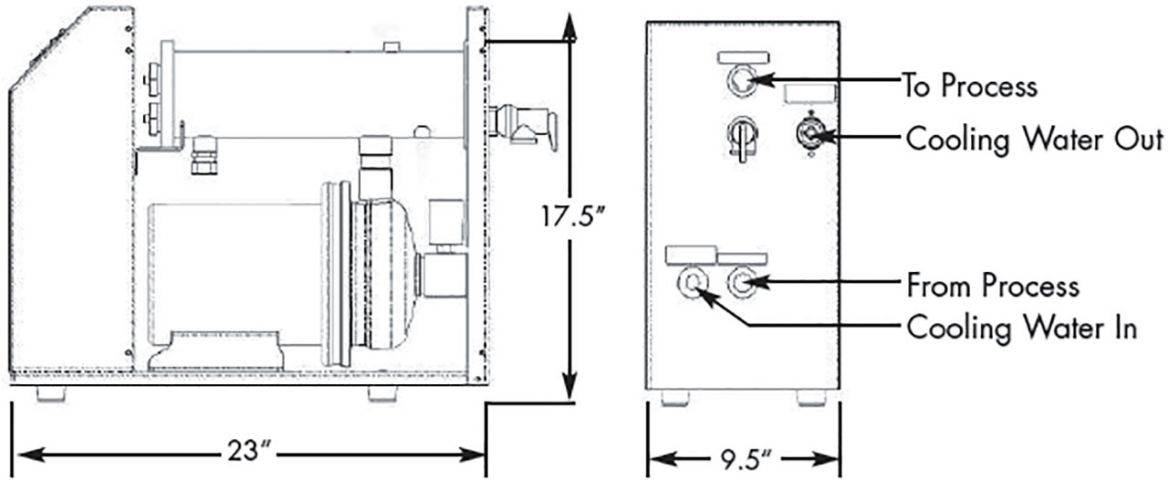

## Specifications

Model Number	Pump, HP (kW)	Flow, gpm (lpm)	Pressure, psig (bar)	FLA 3kW Height, in. (mm)	FLA 6kW Width in. (mm)	FLA 9kW Depth, in. (mm)	Ship. weight, lbs. (kg)
M50	0.5 (0.37)	15 (57)	20 (1.4)	17.5 (445)	9.5 (241)	23 (584)	110 (50)
M75	0.75 (0.56)	20 (76)	23 (1.6)	17.5 (445)	9.5 (241)	23 (584)	110 (50)