



Presto Stantest Pvt. Ltd.

I-42, DLF Industrial Area Phase-1, Delhi Mathura Road, Faridabad 121003, Haryana, India
P : 9210 903 903, +91 129 4272727, 93111 24302 E : info@prestogroup.com

- Faridabad • Kolkata • Mumbai • Pune • Ahmedabad
- Chennai • Bangalore • Hyderabad



Bursting Strength Tester – Digital Pneumatic



Model No. PBP - 600

Bursting Strength Tester – Digital Pneumatic is a consistent tool to indicate the Strength and performance of material like Rexene, leather, paper boards, paper, uneven boards and boxes, industrial fabric and solid fiber boards, filter cloth, plastic films, Foils, sheets, etc. PRESTO Bursting Strength Tester is manufactured under various Test Standards ASTM D 3786-01, ASTM D 3786 – 80A, ISO 1060 PART-1 1987.

Available in Various models like Analogue, Digital, Computerized cum digital model with Manual or Pneumatic Clamping and digital model with printer facility.

- Single Push Button Operation
- Auto Sample Locking under selectable pressure range
- Microprocessor based display for accurate test results
- Peak Hold facility for keeping maximum value of test result in memory
- Memory to hold up to 9 test reading
- Highly accurate test results under multidirectional Pneumatic Force
- Strong Gripping clamps
- Grooved structure of Test Specimen Holder to avoid slippage and intact holding of specimen under test
- Bright LED display
- Feather touch controls
- Calibration lock & key feature

Bursting strength is the force required to burst or rupture the material under testing. Bursting strength of test specimen is expressed in terms of Kg/cm². It is measured by giving hydraulic pressure through a rubber diaphragm on the test specimen.

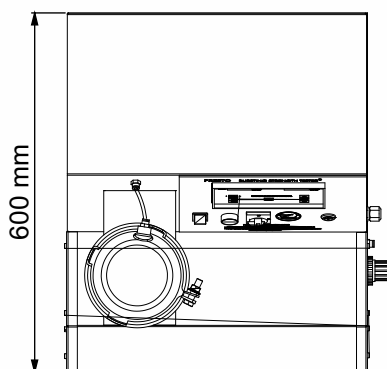

Top View

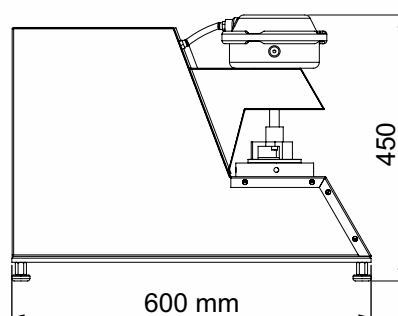

Side View

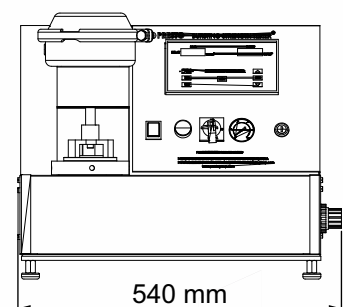

Front View



Presto Stantest Pvt. Ltd.

I-42, DLF Industrial Area Phase-1, Delhi Mathura Road, Faridabad 121003, Haryana, India
P : 9210 903 903, +91 129 4272727, 93111 24302 E : info@prestogroup.com

- Faridabad • Kolkata • Mumbai • Pune • Ahmedabad
- Chennai • Bangalore • Hyderabad



Key Specifications:

Capacity	40 kg/cm ²
Display	LED (Digital)
Specimen Clamping	Pneumatic
Accuracy	± 1% within 10% to 90% of entire ranges as per IS : 1828 with master gauge
Least Count/Resolution	0.1 Kg/cm ²
Pressure Sensor	Pressure Transducer
Power	220V, Single phase, 50 Hz
Test fluid	Glycerin about 98% purified (lab grade)
Rate of fluid displacement	95 cc/minute
Motor	1/4 HP, Single Phase, 1440rpm
Test Range	0.5 Kg / cm ² to 38 Kg / cm ²

Optional Features:

- Digital and Pneumatic computerized models also available (with or without printer facility)

The Bursting strength in Kg/cm² of the test specimen is displayed on the digital display. There after bursting factor and burst index can be calculated by the user.

Standard Accessories :

- 100 ML Glycerin bottle 1no.
- Rubber Diaphragm pack of 2 nos.
- Calibrated Aluminium foil pack of 4 nos.
- Screw Driver 1 no.
- Glycerin bowl opening wrench 1 no.

Highlights:

Memory (to hold test value)	Up to 9 test values
Peak Hold Facility	Yes
Safety Switch	Yes
Material	Mild Steel
Finish	Powder coated Havel Gray & Blue combination finish and bright chrome / zinc plating for corrosion resistant finish
Dimensions	550x600x450 mm
Sample Clamp Pressure	2 - 5 Bar (3 to 4 CFM)

* Air compressor not a part of supply

Thank you customers for choosing us as your partners in growth !



*All the above logos are the sole property of their respective owners and are used purely for depiction purposes only.

OUR OTHER PRODUCTS :-

