

Gravelometer Series	
	EQNA-GR-DIN-VDA
Chamber Temperature Range	Ambient Temp. +9°F - +140°F (+5°C - +60°C) *Accessories Optional: Special Freezer for enclosure, temp range: 23°F to-13°F (-5°C to -25°C)
Exterior Dimensions W x D x H	72.4" x 18.9" x 47.2" 1840mm x 480mm x 1200mm
Crated Dimensions Approximate W x D x H	65" x 25.5" x 57.0" 1650mm x 650mm x 1450mm
Move-in Dimensions W x D x H	68.9" x 29.5" x 61.0" 1750mm x 750mm x 1550mm
Net Weight (Empty)	203 lbs. (92 kg)
Gross Weight (w/ shipping package)	313 lbs (142 kg)
Ambient Temperature Requirements	+75°F - +82°F (+24°C - +28°C)
Ambient Humidity Requirements	max. 85% without condensation
Power	208 - 230V - 50-60Hz - 1 phase
FLA (230V)	2A
Vibratory Projectile Infeed	Standard
Magnetic Safety Lock	Standard
Accessories Optional: Special freezer for enclosure of complete equipment for working up to -25 ° C, with access doors for work.	

3D Sample consult factory

Rev.04

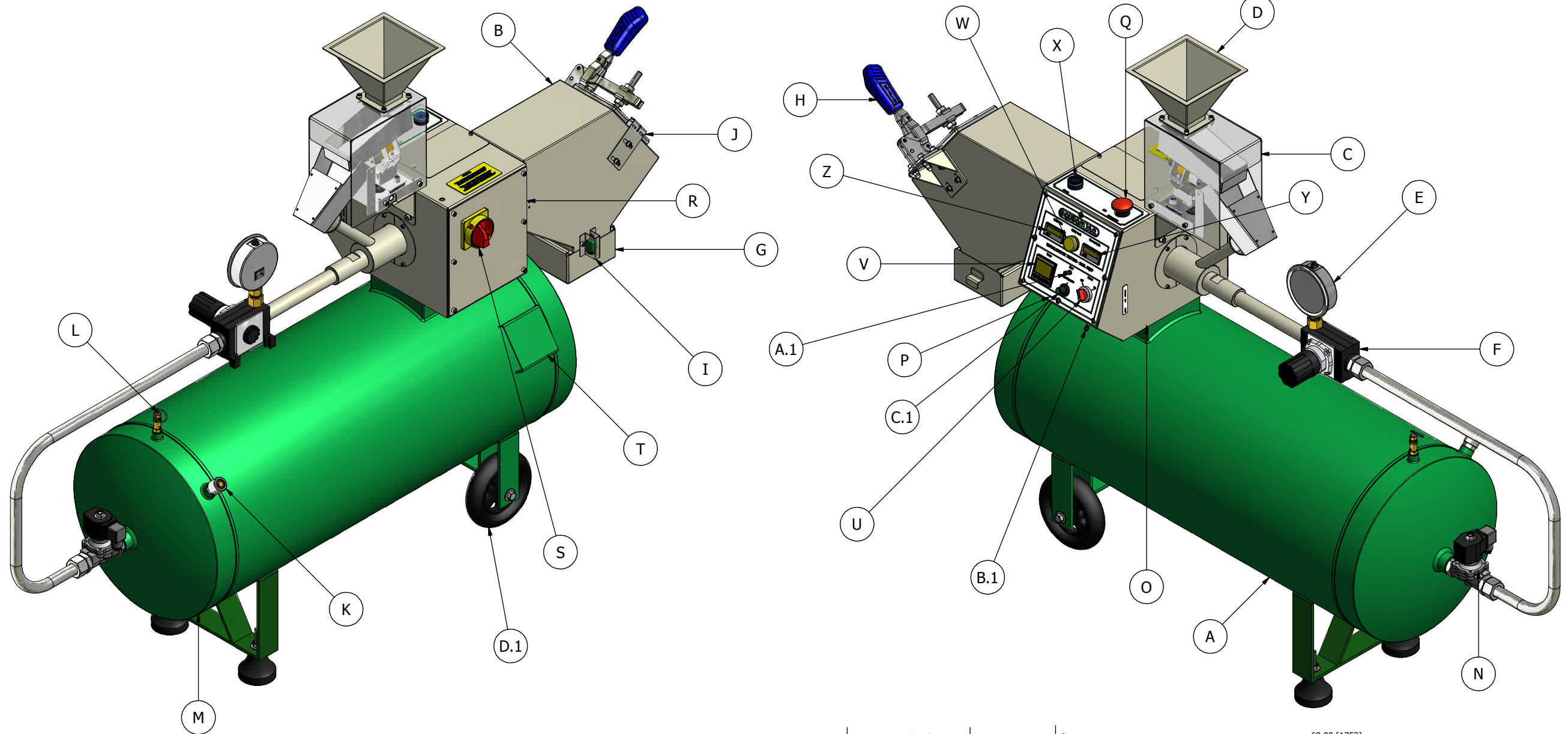

A	Cylinder	Q	Emergency
B	Impact Chamber 54°	R	Power Supply 230Vac - 2FLA - 60Hz - 1 Phase
C	Vibratory Infeed	S	General Switch
D	Silo	T	Identification Data - Cylinder
E	Manometer With Glycerin - 0~150 psi	U	Power: On - Off
F	Regulator Valve - 0~145 psi	V	Timer
G	Collector Tray	W	Safety Lock
H	Clamp	X	Reset
I	Switch	Y	Current Cycle
J	Magnetic Lock	Z	Total Cycle
K	Inlet Compressed Air	A.1	Start
L	Pressure Relief	B.1	Pressure Adjust
M	Drain Valve	C.1	Potentiometer
N	Solenoid valve	D.1	Casters
O	Electric Panel		
P	Control Panel		

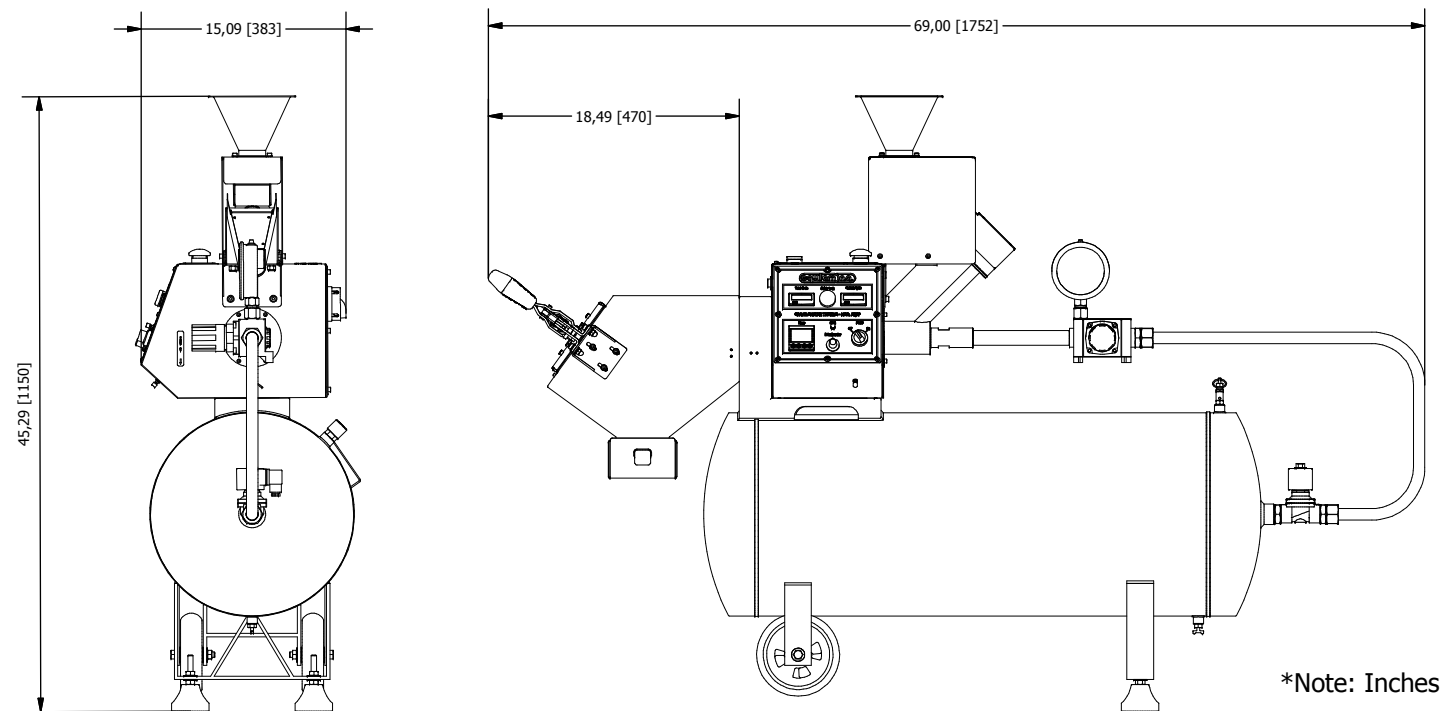

*Note: Inches [mm]



Date:
01/08/2016

Sheet:
A2

No.

www.equilamna.com

Description: Equipment Drawing

Project: EQNA - GR - DIN - VDA

Rev.01