



# CSTR

(Continuous Stirred Tank Reactors)

## Operation and Maintenance Manual





# **CSTR**

(Continuous Stirred Tank Reactors)

Version 3.2, September 2024

Any questions related to this Operation and Maintenance manual should be directed to:

BPC Instruments AB  
Mobilvägen 10  
SE-223 63 Lund  
Sweden

Tel: +46 (0)46 163950  
Fax: +46 (0)46 163959  
E-mail: [support@bpcinstruments.com](mailto:support@bpcinstruments.com)  
Web: [www.bpcinstruments.com](http://www.bpcinstruments.com)

This document contains proprietary information that is protected by copyright.  
All rights are reserved. No part of this publication may be reproduced in any form whatsoever or translated into any language without the prior, written permission of BPC Instruments AB.

Copyright © 2024 BPC Instruments AB

Produced in Sweden

## TABLE OF CONTENTS

<b>1</b>	<b>PREFACE</b> .....	<b>1</b>
1.1	BPC Instruments AB .....	1
1.2	Reactors for continuous fermentation tests .....	2
<b>2</b>	<b>DELIVERY CHECKS</b> .....	<b>3</b>
2.1	CSTR-2G (2 l glass digester) .....	3
2.2	CSTR-5G (5 l glass digester) .....	5
2.3	CSTR-5S and CSTR-10S (5 and 10 l stainless steel digesters) .....	5
<b>3</b>	<b>PRE-COMMISSIONING</b> .....	<b>6</b>
<b>4</b>	<b>QUALITY RULES AND RECOMMENDATIONS</b> .....	<b>6</b>
4.1	Before getting started .....	6
<b>5</b>	<b>SAFETY NOTES AND CONSIDERATIONS</b> .....	<b>6</b>
<b>6</b>	<b>EQUIPMENT DESCRIPTION (DESIGN/FUNCTION)</b> .....	<b>7</b>
6.1	CSTR-2G .....	8
6.2	CSTR-5G .....	9
6.3	CSTR-5S and CSTR-10S .....	11
6.4	Design/function of CSTR .....	13
6.4.1	WALL JACKET .....	13
6.4.2	FEEDING PORT .....	14
6.4.3	GAS OUTLET .....	14
6.4.4	SAMPLING PORT .....	14
6.4.5	VIEWING PORT WINDOW .....	14
6.4.6	BALL VALVES FOR DISCHARGING AND EMPTYING .....	15
6.4.7	SELF DISCHARGING PORT & AUTO SLURRY CONTROL .....	15
6.4.8	ADJUSTABLE FEET .....	15
6.4.9	MOTORS & STIRRERS .....	16
6.4.9.1	Motors & stirrers for CSTR-2G .....	16
6.4.9.2	Motors and stirrers for CSTR-5G, CSTR-5S and CSTR-10S .....	16
<b>7</b>	<b>CSTR TECHNICAL CHARACTERISTICS</b> .....	<b>19</b>
7.1	CSTR configurations .....	19
7.2	Raw materials of the CSTR parts .....	20
7.3	Tri-clamps and gasket sizes .....	20
7.4	Dimensions of the ports on all CSTR digesters .....	21
<b>8</b>	<b>OPERATION</b> .....	<b>22</b>
8.1	First assembly of the CSTR digester .....	22
8.1.1	FIRST ASSEMBLY OF CSTR-2G .....	22
8.1.2	FIRST ASSEMBLY OF CSTR-5G .....	23
8.1.3	FIRST ASSEMBLY OF CSTR-5S AND CSTR-10S .....	23
8.2	Before start up .....	23
8.2.1	CSTR-2G .....	23
8.2.2	CSTR-5G, CSTR-5S AND CSTR-10S .....	24
8.3	Start up .....	25
8.3.1	CSTR-2G .....	25
8.3.2	CSTR-5G, CSTR-5S AND CSTR-10S .....	25
8.4	Feeding and discharging .....	26
8.4.1	CSTR-2G .....	26
8.4.2	CSTR-5G .....	26
8.4.3	CSTR-5S AND CSTR-10S .....	27
8.4.4	DISCHARGING BY USING A GAS BAG .....	27

8.4.5	AUTOMATIC FEEDING .....	28
8.5	Monitoring & troubleshooting .....	28
<b>9</b>	<b>END OF OPERATION.....</b>	<b>29</b>
<b>10</b>	<b>MAINTENANCE AND REPAIRS .....</b>	<b>29</b>
10.1	Disassembly instructions for cleaning and repair .....	29
10.1.1	DISASSEMBLY OF CSTR-2G.....	29
10.1.2	DISASSEMBLY OF CSTR-5G.....	29
10.1.3	DISASSEMBLY OF CSTR-5S AND CSTR-10S .....	30
10.2	Cleaning the reactor .....	30
10.3	Assembly instructions after cleaning and repair .....	31
10.3.1	ASSEMBLY OF CSTR-2G .....	31
10.3.2	ASSEMBLY OF CSTR-5G .....	31
10.3.3	ASSEMBLY OF CSTR-5S AND CSTR-10S .....	31
10.4	Maintenance checks .....	32
10.5	Spare parts for CSTR .....	32
<b>11</b>	<b>EQUIPMENT DISPOSAL .....</b>	<b>36</b>

# 1 PREFACE

## 1.1 BPC Instruments AB

BPC Instruments AB (BPC) is a market leader in the area of gas flow analytical instruments for biotechnology related applications. The company was founded in 2006, and today brings to market almost 20 years of industry leading research and product development in the area of smart analytical instruments. BPC currently has customers in over 60 countries and regions around the world and more are added every year.

BPC's flagship product, the Automatic Methane Potential Test System or AMPTS, is the preferred analytical instrument for conducting various anaerobic batch fermentation tests including biochemical methane potential (BMP) and specific methanogenic activity (SMA) tests. The instrument is widely used by academic and commercial actors who have benefited from significant improvements in data quality and labour savings. BPC also offers a portfolio of exciting smart instruments for low gas flow measurement, in-vitro digestability analysis of animal feed, biochemical oxygen demand (BOD), specific Anammox activity (SAA) analysis and more.

In 2012, BPC launched the BioReactor Simulator (BRS), an analytical device for the control and monitoring of anaerobic fermentation processes in a continuous mode of operation. The BRS is an ideal instrument and platform for gaining knowledge and experience of the continuous operation of biogas production processes. It also serves as the complementary tool to AMPTS, which is used for feedstock characterisation and optimisation. The system is controlled by a web-based software running on an efficient cloud computing solution accessible from any computer or mobile device with an Internet connection.

As of July 2013, AMPTS II Light and  $\mu$ Flow, have been offered to the market for on-line measurements of ultra-low biogas flows produced from the anaerobic digestion of biological degradable substrates.

In 2017, BPC Instruments launches the Gas Endeavour, for on-line measurements of low gas flows produced from any gas generating process at laboratory scale. It is based on the proven AMPTS II technology, and suitable for a wide range of applications, e.g., in animal or human nutrition studies, wastewater treatment, ethanol fermentation, hydrogen production and greenhouse gas emissions.

The CSTR (Continuous Stirred-Tank Reactors) bioreactors are offered in sizes up to 10 l, and are constructed of stainless steel or high-quality glass, all of them might be potentially used to simulate full-scale fermentation processes. These bioreactors have been available on the market since 2013. They have several advantages to other similar reactors on the market:

- The CSTR bioreactors are extremely user friendly and specifically designed with ease of use and maintenance in mind
- Their wall jacket configuration allows for independent heating and cooling
- The CSTR bioreactors are suitable for both low and high solid content feedstock

- The CSTR bioreactors have been designed to be highly flexible for both feeding and process monitoring & control
- The viewing ports allow for visual inspection of foam formation during the fermentation.

The BPC products are designed in a way that offers maximum flexibility without compromising quality. They can be used on their own or connected to each other, in a way that best suit the customer needs.

## **1.2 Reactors for continuous fermentation tests**

The process of anaerobic degradation is highly complex and dynamic, where microbiological, bio-chemical and physico-chemical aspects are closely interrelated. For optimisation purposes, fermentation tests at laboratory scale are used to determine feedstock characteristics and to simulate continuous operation of biogas reactors. In general, for broadly designed test programs, the combination of batch and continuous methodologies should be used. A large number of batch tests running in parallel deliver results on feedstock characteristics, whereas a continuous test simulates long-process conditions spanning larger time frames.

In a conventional continuous fermentation test, the organic matter is added either in stages or continuously to the reactor. The end products are periodically or continuously removed, resulting in a constant and predictable production of biogas. A single digester or multiple digesters in sequence may be used such as:

- CSTR (Continuous Stirred-Tank Reactors)
- UASB (Upflow Anaerobic Sludge Blankets)
- EGSB (Expanded Granular Sludge Beds)
- IC (Internal Circulation Reactors)

The objective of the fermentation tests in the defined continuous procedure is to obtain a reliable long-term database about the gas yield and its composition, and to build up a comprehensive picture regarding the degradation of the organic material, the course of fermentation, and any problems in the degradation process, which may occur. In fact, results from continuous lab-scale fermentation tests have on several occasions been shown to provide a good representation of the full-scale operations. With the help of continuous fermentation tests, it should also be possible to determine how the properties of substrates affect the fermentation process and what process conditions must be put in place in order to achieve an optimal degradation and maximisation of gas yield. Continuous fermentation tests thus deliver the first useful information about the capabilities and loading limits of a process, which is essential for designing and operating a biogas plant as well as for creating models concerning the economical feasibility of a project.

Conventional continuous fermentation tests are laboratory-scale methods subject to large variations, not only due to the heterogeneous nature of bio-wastes and bacteria culture used, but also due to differences in experiment setup and non-unified test protocols. For example, reactor configuration, instrumentation and operational modes can all differ from one laboratory to another. In addition, the presentation of the results is often not standardised, which makes comparability between two tests very difficult. Furthermore, the execution of a fermentation test in continuous mode is often a complex and very labour-intensive and time-consuming procedure, spanning a considerable period of time.



The CSTR bioreactors available at BPC are designed as gas tight reactors that allow for a high liquid and gas mass transfer, as well as for different mixing regimes and mixing intensities at controlled temperature. They can be connected to any type of gas flow measuring device such as Bioreactor Simulator (BRS),  $\mu$ Flow, etc.

## **2 DELIVERY CHECKS**

At delivery, unpack and check that the contents match the lists in the “Box Content” section. Chapter 6 (Equipment Description) shows pictures of the included parts.

If the packaging or the equipment is broken at delivery, please:

1. Document and take photos of the parts and packaging.
2. Inform the transport company at delivery.
3. Make sure that the transport company documents the incident.
4. Inform your local distributor or BPC of the incident.

### **2.1 CSTR-2G (2 l glass digester)**

#### **BOX CONTENT**

Disclaimer: The delivery checklist for CSTR-2G below is valid only when the order is placed for the BioReactor Simulator (BRS) together with sample incubation unit with six 2-litre reactors. If the order is made for another product, where a different number of CSTR-2G is used, the quantities in the list below will be according to that order.

If the order is made for a CSTR-2G glass bottle kit alone, the Bioreactor Agitation Systems (i.e. Brush DC motor-driven agitators or Multifunction Brushless DC motor-driven agitators) are not included.

Two different bioreactor agitation systems are available from Bioprocess Control: i) an initial configuration (in left picture) based on standard brush DC motors with a gearbox and ii) a multifunction version (in right picture) based on a unique design of brushless DC stepper motors.



### **CSTR-2G glass bottle kit**

- 6 glass bottles with 3 ports (2 l reactors)
- 6 glass feeding funnels
- 6 bent glass discharging tubes
- 24 plastic screw caps (18 with and 6 without holes)
- 18 silicone sealing rings
- 6 silicone stoppers
- 6 helical couplings + tool (Allen key 2.5 mm for connecting the helical coupling and stirring rod)

### **Brush DC motor-driven agitators**

- 6 plastic caps with agitators/motors
- 1 motor module
- 1 long motor cable (for connecting the detection unit to the first motor)
- 12 short motor cables (for connecting all 6 agitators in serial)
- 1 power adapter for the motor module
- 6 rubber stoppers with 2 metal tubes, 1 plastic tube and rotating shaft for mixing
- 6 plastic tubing clamps

### **Multifunction brushless DC motor-driven agitators**

- 6 plastic caps with agitators/motors
- 1 Master Control Unit (MCU) Box
- 1 long signal cable (for connecting the detection unit to the first motor)
- 5 short motor cables (for connecting all 6 agitators in serial)
- 1 power adapter
- 6 plastic stoppers with 2 tubing ports, 1 plastic tube and rotating shaft for mixing
- 6 plastic tubing clamps
- 6 helical couplings
- 1 tool (Allen key for connecting the helical coupling and stirring rod)

## 2.2 CSTR-5G (5 l glass digester)

### BOX CONTENT

1 glass reactor  
1 main lid assembly with motor and feeding funnel  
1 metal tri-clamp hinge  
1 gasket for the tri-clamp hinge  
2 plastic screw caps (GL18) with a hole (for water recirculation port)  
2 plastic tube nipples (for water recirculation port)  
1 plastic screw cap GL25 (for pH/ORP sensor port)  
1 plastic screw cap GL25 with hole (for pH/ORP sensor port)  
1 silicone sealing ring for GL25 (for pH/ORP sensor port)  
1 tubing nipple (for emptying & discharging port)  
1 plastic screw cap (GL25) with hole (for emptying & discharging port)  
1 plastic screw cap GL25 (to close the emptying & discharging port)  
1 metal hose connector 12\*25 mm (for the additional port)  
1 mini-triclamp blind (for the additional port)

### Optional parts:

1 tool (Allen key for mounting/dismounting propeller)  
1 metal hose connector 6\*25 to replace the mini-triclamp blind

## 2.3 CSTR-5S and CSTR-10S (5 and 10 l stainless steel digesters)

### BOX CONTENT

1 steel reactor  
1 main lid assembly with motor and feeding funnel  
1 plastic tri-clamp hinge  
1 gasket for the tri-clamp hinge  
1 metal hose connector 18\*25 mm for the additional port  
2 (for CSTR-5S) or 4 (for CSTR-10S) mini-triclamp blinds for the additional ports  
1 metal hose connector 6\*25 mm (ONLY for CSTR-10S) for the additional port

### Optional parts:

1 Allen key (for mounting/dismounting propeller)  
1 metal hose connector 6\*25 mm, or 12\*25 mm, or 18\*25 mm for additional ports

Note: The metal hose connectors for the additional ports are available in three configurations with the following characteristics:

- i) For gas sampling: 6 (OD) /4 (ID) mm \* 25 (OD) mm
- ii) For liquid: 12 (OD) /10 (ID) mm \* 25 (OD) mm
- iii) For slurry: 18 (OD) / 16 (ID) mm \* 25 (OD) mm

### **3 PRE-COMMISSIONING**

The following items are not delivered with the CSTR digesters, however they will/may be required for operating them:

- A recirculating water bath as a heating/cooling source for the CSTR with a wall jacket configuration
- Tubing
  - Silicon tubing for connecting the recirculating water bath to the wall jacket
  - Tygon<sup>®</sup> tubing for connecting the gas outlet to the gas detection unit
  - Tubes for discharging pipes
- Suitable tube clamps and valves
- Long, thin, bendable tool (i.e. plastic strips or cable ties)
- Syringe (100 ml)
- Gas bag

### **4 QUALITY RULES AND RECOMMENDATIONS**

- The product guarantee provided corresponds to the guarantee stipulated on the confirmed product order form and shipping documentation.
- Only the parts delivered with the product can be used in the system in order to guarantee the quality and performance of the product.
- BPC reserves the right to correct any possible text and image errors as well as changes to technical data in this manual.

#### **4.1 Before getting started**

- Read this manual and additional separate manuals for the individual instruments before installing and using the equipment. (E.g. BioReactor Simulator,  $\mu$ Flow And Bioreactor Agitation Systems manuals.)
- Keep the instruction manual for future reference and make sure it is easily available for people who regularly use the CSTR digesters.

### **5 SAFETY NOTES AND CONSIDERATIONS**

The CSTR Bioreactors should be used in an indoor environment with good ventilation, since the content inside them may generate very high volumes of toxic or slightly aggressive gases. The gas outlet on the reactor must always be placed in a fume hood or be connected to a gas bag.

Always wear protective clothing, glasses and gloves when handling bio-waste and inoculum.

A digestion process produces explosive gas, so it is important to **check regularly for clogging** in the discharging tubes. When the reactor is in use, the **lid on the feeding funnel must never be attached with the tri-clamp**. Therefore the CSTR bioreactors are not delivered with the tri-clamp hinge for the feeding funnel. The lid acts as a potential safety valve in case the pressure in the reactors got too high.

The power supply must be unplugged from the motor before assembling or disassembling any parts on the CSTR. Always be cautious when handling electrical devices close to water.

When the motor is running, its rotating parts could potentially cause damage, so make sure to tie back long hair, remove loose hanging clothing, jewellery or similar before operating the motor.

The motor may become hot and it is therefore recommended to not touch its surface directly during operation.

The wall jacket construction of the reactors will attain the same temperature as the water circulating inside it. Normally, the temperature used for experiments is not high enough to cause any damage, but be sure to check that the external heating source has the correct temperature settings and is working properly.

## **6 EQUIPMENT DESCRIPTION (DESIGN/FUNCTION)**

The CSTR bioreactors offered by Bioprocess Control are available in two configurations: glass (G) and stainless steel (S). There are three size options: 2, 5 and 10 l (which are stated in the model names).

## 6.1 CSTR-2G

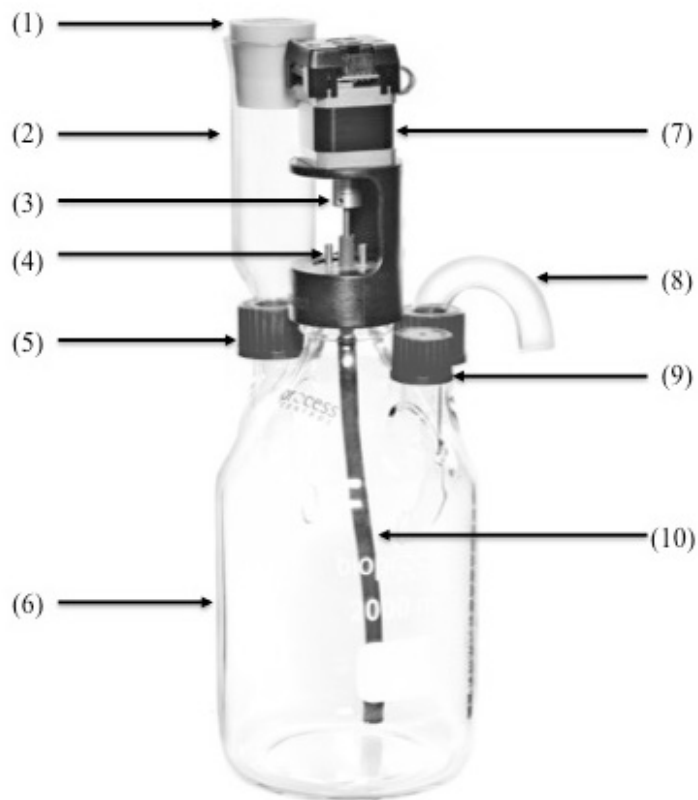

CSTR-2G	
(1) Silicone stopper	(6) Glass bottle
(2) Glass feeding funnel	(7) Motor unit
(3) Helical coupling	(8) Bent glass pipe
(4) Plastic stopper with pipes for gas outlet	(9) Sampling port with plastic cap (T, pH, etc.)
(5) Plastic cap with hole	(10) Stirrer

The glass feeding funnel (2), the silicone stopper (1) and the bent glass pipe (8) are shown separately in the pictures below (from left to right).



## 6.2 CSTR-5G

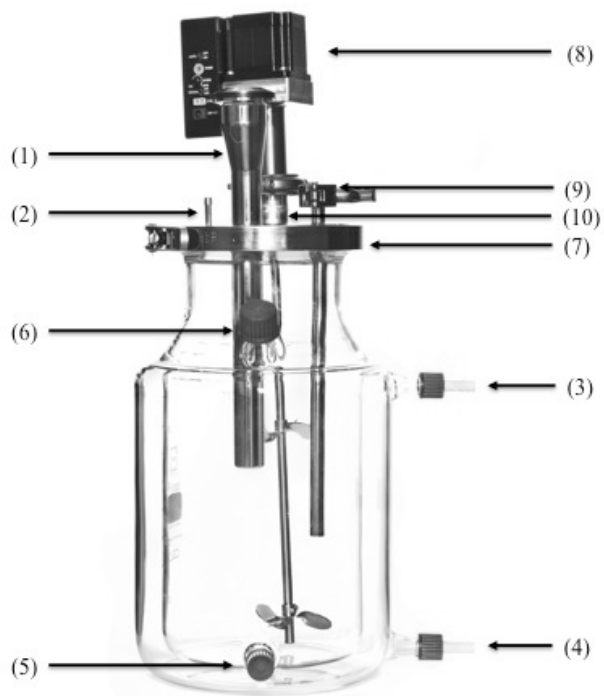



<b>CSTR-5G</b>	
(1) Feeding port for high solid content feedstock	(6) Sampling port (T, pH, etc.)
(2) Gas outlet	(7) Tri-clamp hinge
(3) Heating/cooling water outlet	(8) Motor
(4) Heating/cooling water inlet	(9) Liquid feeding port (for attaching a suitable tube nipple)
(5) Emptying & discharging port	(10) Motor holder

CSTR-5G has 3 ports on the main lid (i.e. gas port, feeding port and one additional port).



### 6.3 CSTR-5S and CSTR-10S

The difference between CSTR-5S and CSTR-10S is mainly their volume and width. Both reactors have detachable emptying (5a) and discharging (5b) ports and two pH/ORP sensor ports. CSTR-5S has 4 ports (i.e. gas port, feeding port and two additional ports) on the main lid, while CSTR-10S has 6 ports (i.e. gas port, feeding port and four additional ports) on the main lid. The pictures and legend below show a CSTR-10S.

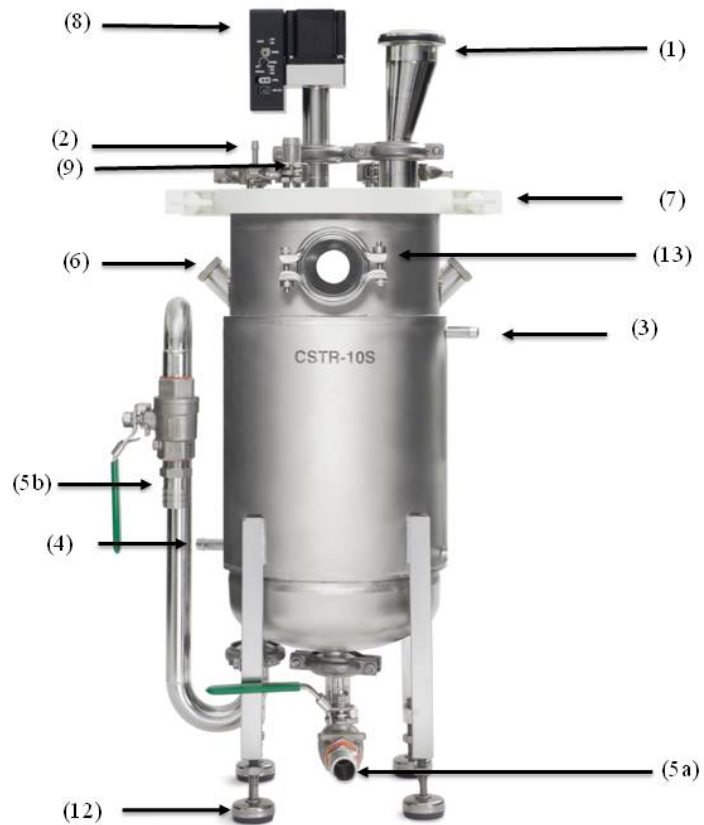

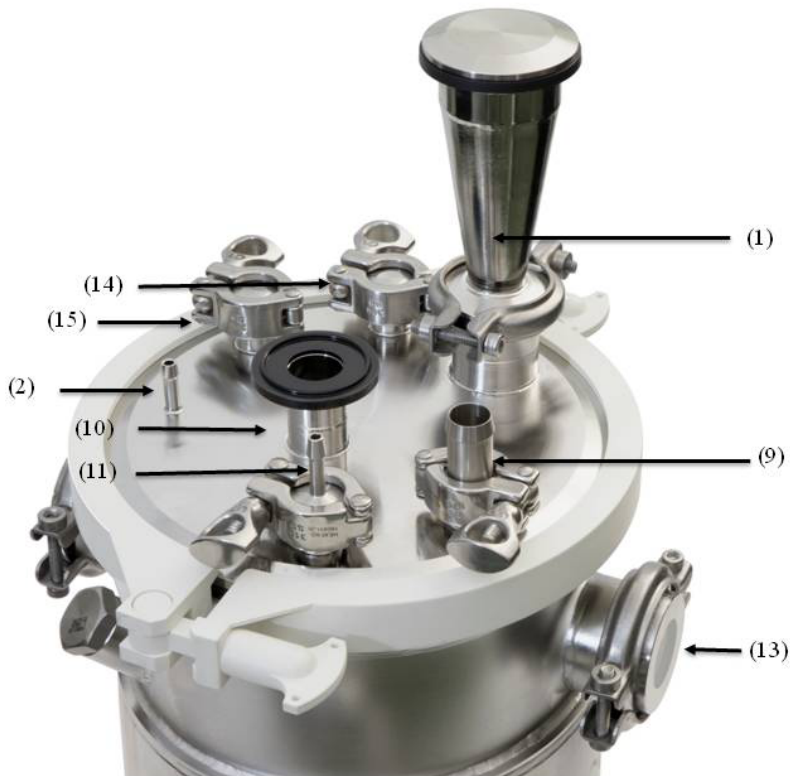

<b>CSTR-5S and CSTR-10S</b>	
(1) Feeding port for high solid content feedstock	(8) Motor
(2) Gas outlet	(9) Liquid feeding port (continues into a tube on the inside of the main lid)
(3) Heating/cooling water outlet	(10) Motor holder
(4) Heating/cooling water inlet	(11) Extra port similar to (9), but does not have a tube attached on the inside of the lid.
(5a) Emptying port	(12) Adjustable feet
(5b) Discharging port	(13) Viewing port window
(6) Sampling ports (T, pH, etc.)	(14) Additional port which has a short tube attached on the inside of the lid (only for CSTR-10S)
(7) Tri-clamp hinge	(15) Additional port (only for CSTR-10S)

The CSTR-10S has one fixed gas outlet (2), one fixed feeding port for high solid content feedstock (1) and four additional tri-clamp connections (9, 11, 14, 15) on the reactor lid. The characteristics of the additional ports are presented as follows: (i) The first tri-clamp connection (9) has a long extension pipe inside the reactor body (i.e. reaching the fermentation media) for liquid/slurry feeding; (ii) The second tri-clamp connection (14) has a short extension pipe inside the reactor body (i.e. not coming in contact with the fermentation media) for liquid/slurry recirculation; (iii-iv) The last two tri-clamp connections (11, 15) can be used as gas inlet/outlet, liquid inlet/outlet or on-line sensors (e.g. pH, T, etc).



The CSTR-5S (see the above photo) has one fixed gas outlet (2), one fixed feeding port for high solid content feedstock (1) and two additional tri-clamp connections (9, 11) on the reactor lid. The characteristics of the additional ports are presented as follows: (i) The first tri-clamp connection (9) has a long extension pipe inside the reactor body (i.e. reaching the fermentation media) for liquid/slurry feeding; (ii) The second tri-clamp connection (11) can be used as gas inlet/outlet, liquid inlet/outlet or on-line sensors (e.g. pH, T, etc).

## 6.4 Design/function of CSTR

### 6.4.1 WALL JACKET

The wall jacket on the CSTR creates a double wall, where water can be circulated for heating or cooling. By connecting the reactor to an external recirculating water bath equipped with a

pump, the temperature in the reactor can be controlled throughout the experiment.

Each CSTR can be heated individually or connected in a series, since many recirculating water bath pumps have the capacity to generate a high enough flow rate (20-30 l/min).

#### 6.4.2 FEEDING PORT

The CSTR Bioreactors have feeding ports in two different sizes. The large one (1) makes it easy for solid feedstock to reach down below the surface of the reactor contents. Liquids can be fed through the smaller port (9), either manually with the help of a syringe, or automatically by a pump.

#### 6.4.3 GAS OUTLET

The gas outlet (2) is designed to have a narrow and gas tight tube (such as Tygon<sup>®</sup>) attached to it, in order to lead the gas into a bag or through a detection unit.

#### 6.4.4 SAMPLING PORT

Through the universal sampling port (6), it is possible to take samples for off-line analysis of parameters such as temperature (T) and pH. A plastic adapter (pictured below) can be used for inserting a pH sensor for on-line monitoring. This plastic adaptor can be supplied upon request.



#### 6.4.5 VIEWING PORT WINDOW

The stainless steel versions have two viewing ports on opposite sides, where foam formation can be detected during the digestion process. Make sure to remove the protective film. To get a clear view inside the tank, shine a lamp through the back window, while inspecting through the front window.



#### 6.4.6 BALL VALVES FOR DISCHARGING AND EMPTYING

The ports for emptying (5a) and discharging (5b) the stainless steel tanks are easily opened and closed using ball valves. “ON” means that the valve is open, and “OFF” means that it is closed. See picture below of the discharging port ball valve.



#### 6.4.7 SELF DISCHARGING PORT & AUTO SLURRY CONTROL

The stainless steel configuration offers an automatic slurry level control. On the inside of the reactor, the discharging tube reaches up along the side of the tank to drain any slurry that reaches above its rim (see picture below).



#### 6.4.8 ADJUSTABLE FEET

The stainless steel configuration has adjustable feet, which make it easy to stabilize and level the reactor.



## 6.4.9 MOTORS & STIRRERS

### 6.4.9.1 Motors & stirrers for CSTR-2G

Two different bioreactor agitation systems for CSTR-2G are available from Bioprocess Control: i) an initial configuration (in left picture) based on standard brush DC motors with a gearbox and ii) a multifunction version (in right picture) based on a unique design of brushless DC stepper motors. For full specifications and description, please refer to the Bioreactor Agitation Systems Manual.



### 6.4.9.2 Motors and stirrers for CSTR-5G, CSTR-5S and CSTR-10S

There are three motor versions available for the 5 l and 10 l reactors: a Brush DC Motor and two versions (i.e. standard and strong) of Multifunction brushless DC motors. Descriptions follow below.

#### BRUSH DC MOTOR



<b>Brush DC motor (technical characteristics)</b>	
Type of motor	Permanent magnet DC motor with planetary gearhead
Voltage	24 V
Output power	12 W
Output torque	0.58 Nm
Output speed	194 min <sup>-1</sup>
Maximum radial load	250 F <sub>R</sub> (N)
Maximum axial load	150 F <sub>A</sub> (N)
Weight	0.59 kg
Length	105 mm
Ambient temperature	-20 to +80 (°C)
Diameter	42 mm
Features	Speed and mixing intervals controlled by an external power supply

<b>Power supply for Brush DC motor (technical characteristics)</b>	
Output voltage	0-24 V (adjustable)
Ripple voltage	1 mV
Output current	0-3 A (adjustable)
Dimensions	130 x 215 x 150 mm
Weight	4.9 kg
Features	LCD display & fine adjustment for voltage and current Protection mode: current-limiting Output connectors IEC1010 Fuse-protected

#### MULTIFUNCTION BRUSHLESS DC MOTORS

Both versions of the multifunction brushless DC motor have a control panel with different settings, shown in the picture and legend below.



(1) Auto (ON/OFF)	This switch is used to control the <b>direction</b> during the rotation of the mixers (i.e. single or bidirectional rotations).	
(2) Timer (0-9)	The timer dial can be set to 10 different intervals, which refer to the rotary switch delays. Below are the intervals for each setting:	
	0	5 s
	1	15 s
	2	30 s
	3	45 s
	4	60 s (1 min)
	5	120 s (2 min)
	6	300 s (5 min)
	7	600 s (10 min)
	8	1800 s (30 min)
9	3600 s (60 min)	
(3) Speed	The rotation speed control dial shows the speed in percentage, where 100% equals full rotation speed of 300 RPM. 5-100% of full rotation equals 15-300 RPM in a linear relation.	
(4) Signal INT/EXT	When signal is set to EXT, the motor can be controlled from an external signal (e.g. the BRS detection unit). INT means that the motor <b>speed</b> can be controlled manually with the adjustment knob.	
(5) CTRL	This is an analogue signal input port, where an external control signal can be connected.	
(6) Power supply	Power supply inlet.	



<b>Technical description for Multifunction Brushless DC Motor standard</b>	
Power supply	24 V
Minimum speed	15 RPM @ V signal output set to 5% (over 0.5 V)
Maximum speed	300 RPM @ V signal output set to 100% (over 12 V)
Maximum power output	35 W
Torque	0.7 Nm
Dimensions	9.3 x 6.7 x 19.5 cm
Weight	2.36 kg

<b>Technical description for Multifunction Brushless DC Motor Strong</b>	
Power supply	24 V
Minimum speed	15 RPM @ V signal output set to 5% (over 0.5 V)
Maximum speed	300 RPM @ V signal output set to 100% (over 12 V)
Maximum power output	71 W
Torque	1.6 Nm
Dimensions	9.3 x 6.7 x 19.5 cm
Weight	2.36 kg

## 7 CSTR TECHNICAL CHARACTERISTICS

### 7.1 CSTR configurations

	<b>CSTR-2G</b>	<b>CSTR-5G</b>	<b>CSTR-5S</b>	<b>CSTR-10S</b>
Reactor type	CSTR	CSTR	CSTR	CSTR
Volume	2 l	5 l	5 l	10 l
Wall jacket volume	NA*	2.7 l	0.7 l	1 l
Materials	High quality glass	High quality glass and stainless steel (AISI 316)	High quality stainless steel (AISI 316)	
Mixing	Mechanical agitation**	Mechanical agitation		
Temperature control	External			
Dimension H x W	26 x 13 mm (without motor)	38 x 24 mm	74.5 x 28.5 mm	77.5 x 32.5 mm

	45 x 13 mm (with motor)			
Weight	1.3 kg	7.8 kg	12.8 kg	16.5 kg

\*Heating control is performed using a thermostatic water bath where the 2 litre reactors are placed. It is supplied by BPC together with a stabilizing and evaporation minimizing lid with 6 circular openings for reactors.

\*\*Agitators/motors can be provided with CSTR-2G upon request.

## 7.2 Raw materials of the CSTR parts

- NG600WH plastic is moulded from glass-reinforced Nylon USP.
- EPDM rubber is ethylene propylene diene monomer rubber.
- AISI316 is an acid proof stainless steel material with a high resistance to corrosion and heat.
- Borosilicate glass is a type of glass, which is less sensitive to thermal shock.
- PTFE and FEP is polytetrafluoroethylene and fluorinated ethylene propylene, respectively, a material known as Teflon.

For more details on the materials, please check chapter 10.5 for.

## 7.3 Tri-clamps and gasket sizes

A tri-clamp connection consists of two ferrules joined by a clamp with a gasket. Tri-clamp size was determined by the outside diameter of the pipe, NOT the outside diameter of the ferrule. See picture below for a schematic representation of a tri-clamp connection.

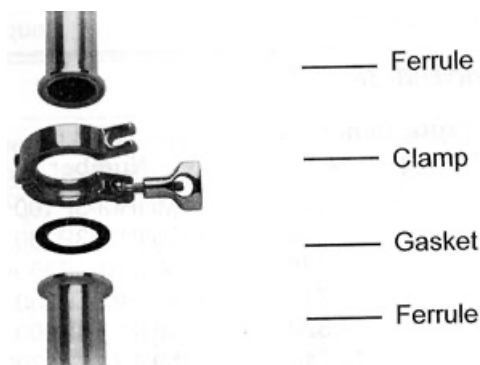

The ferrule (i.e. the metal ring put around the pipe) is about 12.7 mm (1/2'') larger than the tri-clamp size. In the picture below, (A) represents the internal diameter (ID) of the metallic pipe and (B) is the outer diameter (OD) of the ferrule.



<b>Tri-clamp and gasket sizes (mm)</b>			
<b>Usage</b>	<b>Tri-clamp size</b>	<b>Pipe ID (A)*</b>	<b>Ferrule OD (B)*</b>
Liquid feeding port	12	9.5	25.1
Emptying & discharging ports on the version of CSTR-5S and CSTR-10S where the ports are detachable	25	20	34
<ul style="list-style-type: none"> <li>• Feeding funnel lid for 5 l reactors</li> <li>• Feeding funnel holder</li> <li>• Motor holder</li> </ul>	38	34.9	50.5
<ul style="list-style-type: none"> <li>• Feeding funnel lid for 10 l reactors</li> <li>• Viewing port holes</li> </ul>	51	46.6	64.0
Plastic hinge clamp for CSTR-5S	150	149.2	166.1
Plastic hinge clamp for CSTR-10S	200	200.0	217.5

\*In picture above

#### 7.4 Dimensions of the ports on all CSTR digesters

<b>Ports (mm)</b>	<b>CSTR-2G</b>	<b>CSTR-5G</b>	<b>CSTR-5S</b>	<b>CSTR-10S</b>
<b>Feeding funnel</b>	ID/OD 12/15 or 16/19	ID 22	ID 22	ID 22
<b>Liquid feeding</b>	NA	ID/OD 10/12	ID/OD 16/18	ID/OD 16/18
<b>Gas outlet</b>	ID/OD 3/4	ID/OD 4/6	ID/OD 4/6	ID/OD 4/6
<b>Wall jacket</b>	NA	ID/OD 8/10	ID/OD 10/12	ID/OD 10/12
<b>Emptying &amp; discharging</b>	ID/OD 12/15 or 16/18	ID/OD 12/15	ID/OD 20/25	ID/OD 20/25

When tubing is attached to the ports on the reactors, it is important that it has an airtight fit to maintain anaerobic conditions in the reactor during the experiment. A suggestion is that the tubing should have an inner diameter (ID), which is 2 mm smaller than the outer diameter (OD)

of the port it will be attached to. e.g. the liquid feeding port for the CSTR-5S has an OD of 12 mm, which means that the tubing should have an ID of 10 mm.

Tygon<sup>®</sup> tubing must be used on the gas outlet ports, but the other ports can use any type of silicone tubing used for laboratory purposes.

## 8 OPERATION

### 8.1 First assembly of the CSTR digester

All 5 and 10 l reactors are delivered partly assembled, so final assembly will be easy. The main lid is placed on the tank with a gasket in between, and then sealed by a tri-clamp hinge. Be careful when inserting the propellers into the tank and check that they do not hit the discharging tube, or come too close to it when the main lid is closed.

The CSTR-2G (2 l glass reactors) differ most from the others in design and how to assemble.

#### 8.1.1 FIRST ASSEMBLY OF CSTR-2G



1. Put the reactor bottle on a stable surface.
2. Put a screw cap on the bent glass pipe, and then add a silicone gasket with the hard plastic side towards the screw cap.
3. It is recommended to use the openings that are at angle of 180° from each other, to have some distance between the feeding and the discharging tubes. (See picture above.) Insert the long, straight side of the glass pipe into one of the openings shown in the picture to

the above left. Push it gently as far down as possible into the digester and make sure it is parallel to the side of the reactor sidewall. Screw the cap tight onto the reactor.

4. Repeat step 2 above on the glass feeding funnel. Insert the pipe as far down as possible.
5. Close the third small opening by attaching a screw cap, or attach a sensor (T, pH, etc.) by using a screw cap with a hole.
6. (The picture above shows the reactor with a motor unit attached. Please refer to the Bioreactor Agitation Systems manual for details about the motor unit.)

#### 8.1.2 FIRST ASSEMBLY OF CSTR-5G

1. Put the reactor tank on a stable surface.
2. Put the large gasket on the rim around the opening of the reactor.
3. Gently work the stirrer and the feeding tubes into the opening of the reactor until the main lid rests on the gasket on top of the reactor rim. Take care to ensure that the gasket seals properly and is not in the wrong position.
4. Fasten the main lid with the tri-clamp hinge.
5. Put the screw cap on the emptying port.
6. Insert the tube nipples into the screw caps with holes, and put them on the two ports (3) & (4), which lead in and out of the reactor wall jacket.

#### 8.1.3 FIRST ASSEMBLY OF CSTR-5S AND CSTR-10S

1. Put the reactor tank on a stable surface and adjust the feet if necessary.
2. Attach the emptying and discharging pipes if the reactor was shipped with these ports removed (valid only for the versions with detachable ports).
3. Put the large gasket on the rim around the opening of the reactor.
4. **Before inserting the stirrer and feeding tubes** into the reactor, look inside the tank to note the discharging pipe that runs close to the inside wall. The propeller blades and the feeding tubes must be placed so they cannot touch that tube. Take care to ensure that the gasket seals properly and is not in the wrong position.
5. Close the main lid by attaching the plastic tri-clamp hinge around it.
6. Remove the protection film from the viewing porthole windows.

## 8.2 Before start up

### 8.2.1 CSTR-2G



1. Use protective clothing, gloves and glasses when handling bio-waste and inoculum.
2. Place the reactor on a stable and horizontal surface in an environment with good ventilation. See chapter 8.1.1 for reactor preparations before starting the experiment.
3. Cut 6 pieces of tubing of a dimension that fits the size of the bent glass pipe, and attach them to the end of the pipe. Close the tube with a clamp or a valve. This will be helpful during the discharging procedure. (Described in chapter 8.4).
4. If needed, attach a sensor (T, pH, etc.) to the sampling port.
5. Fill the reactor with inoculum and substrate in the proportions needed for the experiment.
6. Lubricate rubber stoppers on the side that is in contact with the glass bottle, preferably with silicone spray or silicone stick.
7. Place the rubber stopper (with two metal tubes and a stirrer) in the opening of each bottle and press the rubber part in order to close the bottle. Avoid pressing the metallic rod as this will lead to separation of the white plastic cap from the bottom of the stirring rod and allow gas or liquid leakage from the reactor. (First picture from the left above.)
8. Pull out the metallic rod from the bent stirrer into the helical coupling and attach it. (Second picture from the left.)
9. Place the plastic screw thread cap/motor support over it and screw until the thread on the bottle is no longer visible and the lid is properly sealed. (Third picture from left above.) Refer to the Bioreactor Agitation Systems manual for more details on the motor units.
10. Connect the bent stir rod to the motor by carefully tightening the two screws on the helical coupling. Make sure that the helical coupling is not touching the plastic motor support or the metallic screws holding the motor in place, to avoid friction from the movement of the helical coupling.
11. Put each reactor in a thermostatic water bath (fitted with the 6 hole lid) after preparing it to this stage.
12. Cut 6 pieces of Tygon® tubing of sufficient length to connect one of the small metal tubes on top of the rubber lids of each reactor to a detection unit. See chapter 8.4 (Feeding and discharging) for suggestions on gas outlet set up.
13. Cut 6 pieces of Tygon® tubing at lengths of about 10 cm and connect them to each of the free small metal tubes on top of the rubber lids of the reactors. Close the tubing pieces with the help of plastic tubing clamps.

### 8.2.2 CSTR-5G, CSTR-5S AND CSTR-10S

1. Use protective clothing, gloves and glasses when handling bio-waste and inoculum.
2. Place the reactor on a stable and horizontal surface in an environment with good ventilation.
3. Use a tri-clamp and a gasket to fasten a tube nipple to the liquid feeding port. (If the stainless steel version with 4 ports on the main lid is used, check that the selected port continues into a metal tube on the inside of the lid.)
4. If needed, attach a sensor (T, pH, etc.) to the sampling port.
5. Check that the ball valve handle on the emptying and the discharging ports are in the “off” (closed) position (on the steel configuration) or that the emptying and discharging port on the glass configuration is closed by a screw cap or a clamped tube attached by a tube nipple.

6. Fill the reactor with inoculum and substrate in the proportions needed for the experiment. The recommended filling level is to reach the top edge of the discharging tube that is mounted along the inside of the tank, as seen in the picture in chapter 6.4.7.
7. Put the main gasket on the rim of the reactor and carefully insert the stirrer and feeding tubes into the tank. Close the main lid and fasten the tri-clamp hinge.
8. See chapter 7.4 for suggestions on gas outlet set up. Cut Tygon<sup>®</sup> tubing long enough to reach from the gas outlet on the reactor to the detection unit, or to fit a set up where a T-connection is used to connect both a detection unit and a gas bag. Close it with a tube stopper.
9. Attach the Tygon<sup>®</sup> tubing on the gas outlet and close the tubing with a clip.
10. Check that the sampling port is closed by a sealing bolt or the plastic adapter with a sensor (T, pH, etc.).
11. Connect tubes to the in- and outlet ports to the wall jacket and prepare the recirculating water bath.
12. Add tubing to the discharging ports to help during the discharging procedure (described in chapter 8.4).
  - CSTR-5S or CSTR-10S: Connect a piece of tubing to the end of the discharging tube.
  - CSTR-5G: This type of reactor can either be discharged by using suction created by holding a syringe to the liquid feeding port, or by connecting a piece of tubing to the emptying port (by a tube nipple and a screw cap with a hole). If the latter method is chosen, it is important to close the tube with a valve, and to place the reactor close enough to the edge of a bench, so discharging can be done into a jar placed at a level lower than the tank.
13. Check that all feeding ports are covered by a lid or are connected to a tube (if a feeding pump is used), but **do not use tri-clamps to fasten any feeding port lids during the experiment!**

## 8.3 Start up

### 8.3.1 CSTR-2G

1. If CSTR-2G is used as part of the BioReactor Simulator, refer to that manual when starting up the system.
2. Refer to the Bioreactor Agitation Systems Manual for a full description of connecting and starting the Brush DC Agitation System or the Multifunction Brushless DC Agitation System, depending on which one of them that is used.
3. Always make sure the agitation systems are disconnected from the mains while assembling and connecting them. If the Multifunction Brushless DC Agitation System is used, it is also recommended to set the switch on each motor unit and on the Motor Controller to OFF before connecting or disconnecting the components of the system.

### 8.3.2 CSTR-5G, CSTR-5S AND CSTR-10S

1. Turn on the recirculating water bath and set the correct temperature.
2. Choose motor settings according to description in chapter 6.4.9.

3. Connect the power supply for the motor(s).
4. If a 5 or 10 l reactor is used, make sure the lid on the feeding funnel is **not** attached with a tri-clamp in order to let accidental over-pressure out of the reactor.

## 8.4 Feeding and discharging

The methods and procedures for feeding and discharging the reactors may vary depending on the reactor configuration and whether they are fed manually or automatically. The procedures described below are suggestions, which can be used as a starting point. Some of the equipment mentioned below is listed in chapter 3, as it may not be included in the CSTR delivery package.

### 8.4.1 CSTR-2G

1. Close the tubing clip (8) to the detection unit.
2. Hold a container under the opening of the bent glass pipe. (See picture in chapter 6.1.)
3. Add feedstock through the feeding funnel. If it does not sink into the reactor by itself, it can help to tap the silicone stopper into the funnel opening, to gently force it down.
4. Make sure that the amount of slurry that comes out equals the amount of feedstock that was added. If the glass pipe is clogged, insert a syringe into the tubing that is attached to the pipe, and use suction to clear it. A cable tie can be inserted to help unclogging.
5. Open the tubing clip to the detection unit (8) so gas registration can continue.

### 8.4.2 CSTR-5G

1. Close the tubing clip (8) to the detection unit.
2. Add feedstock through the feeding funnel (1). It may be necessary to alternate between this step and step 3 to equal the pressure in the tank so the feedstock can enter properly through the funnel tube into the reactor contents.
3. Discharging can be done in two ways. The first one is the safest since it does not risk emptying the reactor by accident.
  - a. Attach a piece of tubing to the liquid feeding port, and then insert a syringe and extract it by suction.
  - b. Hold a container under the tube attached to the emptying port (5), and open the valve slowly.
4. Make sure that the amount of slurry that comes out equals the amount of feedstock that was added.
5. Open the tubing clip to the detection unit (8) so gas registration can continue.



### 8.4.3 CSTR-5S AND CSTR-10S

The stainless steel reactors have a separate discharging port with an automatic level control, which helps balancing the amount of substrate that is added and discharged.

1. Close the tubing clip (8) to the detection unit.
2. Hold a container under the opening of the discharging tube, and open the valve (3).
3. Add substrate to the reactor.
4. If any clogging has developed in the discharging tube, use a syringe to create suction in the tube piece that has been connected to the end of the discharging tube, or try to insert something like a cable tie to clear out the clogging. Leave the valve open until no more slurry stops coming out. The discharged amount should roughly equal the amount that was fed to the reactor.
5. Open the tubing clip to the detection unit (8) so the gas registration can continue.

### 8.4.4 DISCHARGING BY USING A GAS BAG

The 5 and 10 l reactors can be set up with a gas bag according to the picture below. (In one version of the steel configuration, the extra port on the lid can be used instead of a T-connector as shown below.)

At the start of the experiment, the gas bag can be filled by letting the bag be expanded by gas generated from the start of the experiment, which takes 1-2 days. It can also be manually filled with a standard gas.

The bag will provide a gas buffer, which can balance any negative pressure in the tank during discharging. It can also be pushed as a way to apply force during discharging, in case any clogging needs to be cleared. The tube clamp at the gas bag (9) is optional.

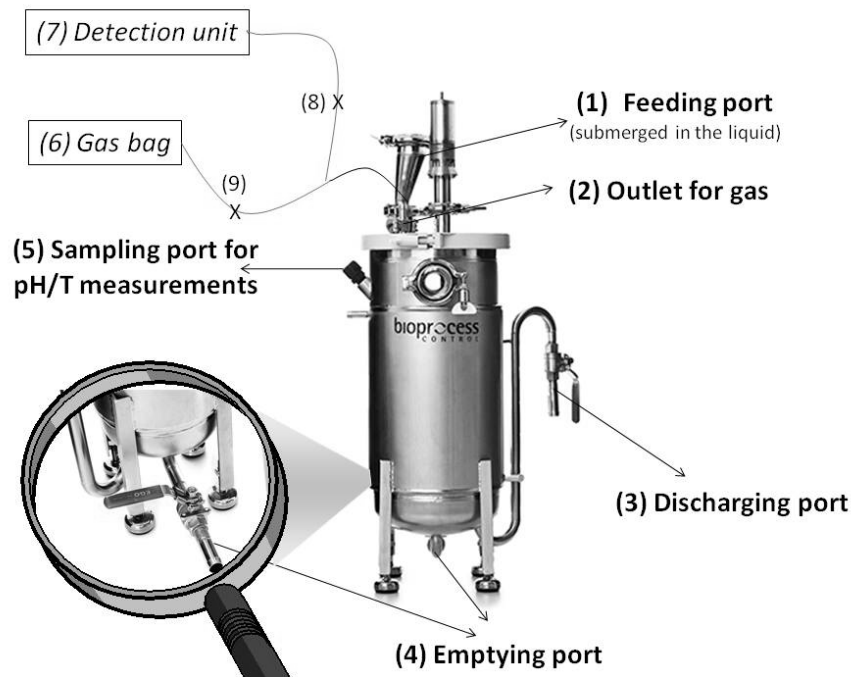

#### 8.4.5 AUTOMATIC FEEDING

When automatic feeding is used, a pump will push the feedstock into the reactor, and discharging can be done at a separate time, in the way described in the previous sections of this chapter. If the stainless steel reactors are used, the automatic slurry level function can be used, by leaving the ball valve on the discharging port open. However, the reactor still needs to be monitored regularly to limit clogging problems.

When an automatic feeding routine is used, the tube connecting the reactor to the detection unit must be left open at all times.

### 8.5 Monitoring & troubleshooting

- If discharging is difficult, clogging may be the problem. Attaching a tube to the discharging port and inserting a syringe to create suction can help removing the problem. The set up with a gas bag described in chapter 8.4.4 can also be helpful if clogging occurs.
- With the steel reactor configuration, the emptying port can be used as an alternative discharging port, but it must be opened **very** slowly to avoid emptying all of the reactor contents.
- Foam formation can be detected through the viewing port. Shine a lamp through the back window to get a better view through the front window into the reactor.
- If the windows are smudged, they can be briefly removed for cleaning, but it will let some oxygen into the reactor, so try to be quick.
- Check that the mixing is working properly, and adjust the speed or intervals if necessary.
- Refer to the Bioreactor Agitation Systems manual for details on the motors (e.g. how the reset button works, and how to change the fuse in the Motor Controller).

## 9 END OF OPERATION

- Always wear protective clothing (lab coat, glasses and gloves) when emptying the reactor.
- The motors on the 5 and 10 l reactors are turned off by unplugging the motors from the power mains.
- If the CSTR-2G is used as part of the BRS, the motors must first be turned off from the software interface. (See BRS manual for full description in the Software section.)
- The agitation systems for CSTR-2G are turned off in different ways:
  - The Multifunction Brushless DC Agitation System is powered off at the switch on the Motor Controller. It is recommended to also unplug the Motor Controller from the mains, and to set the switch on each motor unit to the OFF position. (See Bioreactor Agitation Systems manual for full description.)
  - The Brush DC Agitation System is powered off by unplugging the power adapter from the mains.
- Dispose of the bio-waste in an appropriate way (e.g. by taking it back to a biogas plant).
- Disassemble the reactor according to instructions in chapter 10 and clean the parts. Use water and regular washing liquid. Inspect the gaskets and screw caps and check the spare parts list if new ones are needed.
- When the reactor is not in use, store it disassembled in a dry place.

## 10 MAINTENANCE AND REPAIRS

### 10.1 Disassembly instructions for cleaning and repair

Always unplug the power supply from the motor before assembling or disassembling any parts of the CSTR reactor.

#### 10.1.1 DISASSEMBLY OF CSTR-2G

1. Before disconnecting any cables from the motor system, turn off the motors according to the procedure described in the Bioreactor Agitation Systems manual.
2. Remove any tubing that is attached to the reactor.
3. Remove the feeding funnel and the bent glass pipe.
4. Turn the helical coupling to find the screws that fasten the stir rod, and unscrew them.
5. Remove the plastic motor screw caps from the reactor opening.
6. Remove the metal rod from the helical coupling.
7. Pull out the bent stir rod from the reactor bottle.
8. Empty the reactor according to chapter 9.

#### 10.1.2 DISASSEMBLY OF CSTR-5G

1. Turn off the motor.
2. Remove any tubing that is attached to the reactor.
3. Remove lids, tube nipples and gaskets from the feeding ports, and take out the large feeding funnel from the main lid.
4. Remove the tri-clamp hinge from the main lid.

5. Lift the main lid and be careful when pulling the stirrer out of the tank. Place the main lid with the stirrer still attached on a horizontal surface. The propellers can be removed with an Allen key (2.5 mm) that is delivered with the CSTR.
6. Remove the tri-clamp that attaches the motor shaft to the main lid.
7. When the propellers have been removed, pull out the stirrer and remove the gasket from the motor holder.
8. Remove the main lid gasket.
9. Remove the screw caps and tube nipples from the emptying port and the wall jacket ports.

#### 10.1.3 DISASSEMBLY OF CSTR-5S AND CSTR-10S

1. Turn off the motors.
2. Remove any tubing that is attached to the reactor.
3. Remove lids, tube nipples and gaskets from the feeding ports, and remove the large feeding funnel from its holder on the main lid.
4. Remove the tri-clamp hinge from the main lid.
5. Lift the main lid and be careful when pulling the stirrer out of the tank. Place the main lid with the stirrer still attached on a horizontal surface. The propellers can be removed with the Allen key (2.5 mm) that is delivered with the CSTR.
6. Remove the tri-clamp that holds the motor shaft to the main lid.
7. When the propellers have been removed, pull out the stirrer and remove the gasket from the motor holder.
8. Remove the main lid gasket.
9. Remove the tri-clamps, windows and gaskets from the viewing ports on the sides of the reactor.
10. Unscrew the bolt from the sampling port.
11. If there are any tri-clamps around the tubes located at the bottom of the reactor, remove them with their tubes and gaskets. (Note: there is one version of the CSTR where the emptying and discharge tubes are fixed to the tank, and cannot be removed.)

## 10.2 Cleaning the reactor

The motor should be protected from water even though it is water resistant according to IP class. Be careful when cleaning the stirring rod. The bent stir rod for the CSTR-2G reactor should be detached from the motor coupler before washing.

The glass and stainless steel parts of the reactor can be cleaned with regular washing liquid. Remember to leave the ball valves on the emptying and discharging ports in the “on” (open) position when cleaning them.

## 10.3 Assembly instructions after cleaning and repair

Always unplug the power supply from the motor before assembling or disassembling any parts of the CSTR tank.

### 10.3.1 ASSEMBLY OF CSTR-2G

1. Put the reactor on a stable surface.
2. Put a screw cap on the bent glass pipe, and then a silicone gasket with the hard plastic side towards the screw cap. (See the picture in chapter 8.1.1.) Then insert the glass pipe and screw the cap tight onto one of the 3 small openings.
3. Repeat step 2 above on the glass feeding funnel.
4. Put a screw cap on the third small opening. If you want to attach a sensor (T, pH, etc.), attach a cap with a hole in the top and a silicone gasket the same way as described in step 2.
5. Repeat the steps in chapter 8.2.1 to assemble the reactor completely before start-up.

### 10.3.2 ASSEMBLY OF CSTR-5G

1. Put the reactor tank on a stable surface.
2. Put the screw cap on the emptying port.
3. Insert the tube nipples into the screw caps with holes, and put them on the two ports that lead in and out of the wall jacket.
4. Put the large gasket on the rim around the opening of the reactor.
5. If the propellers and the motors have been detached from the main lid, put a gasket on the motor holder and then insert the stirrer. Fasten the motor with a tri-clamp.
6. Attach the propellers to the stirrer, using the Allen key (2.5 mm). The top propeller should be placed about half way down the stirrer.
7. Gently work the stirrer and pipes into the opening of the reactor until the main lid rests on the gasket on top of the reactor.
8. Attach the tri-clamp around the edge of the main lid and adjust it if needed.
9. Put a gasket on the feeding funnel hole and insert the feeding funnel. Fasten with a tri-clamp.
10. Put a gasket on the small feeding port and add a tube nipple. Fasten with a tri-clamp.

### 10.3.3 ASSEMBLY OF CSTR-5S AND CSTR-10S

1. If you have a CSTR with removable ports for discharging and emptying, attach the gaskets and tubes, and fasten them by the tube clamps. The shortest, L-shaped tube should be attached to the outlet at the centre of the reactor bottom, and the longer tube with two U-bends should be fastened at the outlet to the side of the reactor bottom.
2. Put the viewing port gaskets and windows back on the sides of the reactor, and fasten with the tri-clamps.
3. If the propellers and motor have been detached from the main lid, put the gasket on the motor holder, and insert the stirrer. Then fasten with a tri-clamp.
4. Put the propellers back on the stirrer and fasten them with the Allen key (2.5 mm). The top propeller should be placed about half way down the stirrer.
5. Put the main lid gasket on the rim of the tank.

6. **Before inserting the stirrer and feeding tubes** into the reactor, look inside the tank to note the pipe that runs close to the inside wall. (See picture in section 6.4.7.) The stirrer and the feeding tubes must be placed so they cannot touch that tube.
7. Fasten the main lid by attaching the tri-clamp hinge around it.
8. Put the gasket on the feeding funnel hole on the main lid, and insert the feeding funnel. Fasten with a tri-clamp.

## 10.4 Maintenance checks

Keep the reactors clean when they are not in use. Make sure that the gaskets and ball valves are intact.

Refer to the Bioreactor Agitation Systems manual for the agitators for the CSTR-2G.

## 10.5 Spare parts for CSTR

CSTR offered by Bioprocess Control are fabricated from stainless steel (S) or glass (G) and are available in three size options (2, 5 and 10 l) and 4 different configurations:

- CSTR-2G
- CSTR-5S
- CSTR-10S
- CSTR-5G

Inquiries about parts that are not listed below can be addressed to your local distributor, directly to Bioprocess Control, or through our web site ([www.bpcinstruments.com](http://www.bpcinstruments.com)).

The main spare parts for these digesters are presented in the tables following below:

<b>CSTR-2G</b>					
<b>No.</b>	<b>Description</b>	<b>Size (mm)</b>	<b>Material</b>	<b>Qty</b>	<b>Placed</b>
1	Feeding funnel (narrow)	ID/OD 10/12	Glass	1	Small port
2	Feeding funnel (wide)	ID/OD 16/19	Glass	1	Small port
3	Bent glass pipe (narrow)	ID/OD 10/12	Glass	1	Small port
4	Bent glass pipe (wide)	ID/OD 16/19	Glass	1	Small port
5	Screw cap with hole (GL25)	ID 15	Plastic	3	Small port

6	Screw cap with hole (GL32)	ID 20	Plastic	3	Small port
7	Screw cap (GL25)	N/A	Plastic	1	Small port
9	Silicone ring gasket (GL25)	ID 12	Silicone	3	Small port
10	Silicone ring gasket (GL32)	ID 18	Silicone	3	Small port
11	Silicone green stopper	Bottom diameter 38	Silicone	1	Feeding funnel
12	Silicone blue stopper	Bottom diameter 44	Silicone	1	Feeding funnel

<b>CSTR-5G</b>					
<b>No.</b>	<b>Description</b>	<b>Size (mm)</b>	<b>Material</b>	<b>Qty</b>	<b>Placed</b>
1	Tri-clamp gasket	38 (50.5*35.3)	EPDM rubber	1	Feeding (up)
2	Tri-clamp gasket	25 (50.5*22.5)	EPDM rubber	1	Motor
3	Mini-tri-clamp gasket	12 (22*10.2)	EPDM rubber	1	Extra port on the lid
4	Tri-clamp hinge bolted	38	AISI304 stainless steel	1	Motor
5	Mini-tri-clamp hinge	18	AISI304 stainless steel	1	Extra port on the lid
6	Tri-clamp blind	38	AISI316 stainless steel	1	Feeding (up)
7	Mini-tri-clamp blind	18	AISI316 stainless steel	1	Extra port on the lid
8	Motor holder		AISI316 stainless steel	1	Motor
9	Quick release clamp	150	Stainless steel	1	Lid
10	O-ring	150	FEP/Silicone	1	Lid
11	Shaft gasket	8	EPDM rubber	3	Stirrer
12	Shaft coupling		Stainless steel	1	Stirrer
13	Shaft	600	Stainless steel	1	On motor via coupling

14	Propeller	76 (7.9) 3''(5/16'')	Stainless steel	1	Stirrer
15	Red screw cap (GL25)		Plastic	2	Sensor port/ Discharging port
16	Red screw cap with hole (GL25)		Plastic	1	Sensor port
17	Silicone sealing ring for GL25	(22*12)	Plastic	1	Sensor port
18	Red screw cap with hole (GL18)		Plastic	2	Heating water inlet/outlet
19	Tubbing connector	10/16	Plastic	2	Heating water inlet/outlet

<b>CSTR-5S</b>					
<b>No.</b>	<b>Description</b>	<b>Size (mm)</b>	<b>Material</b>	<b>Qty</b>	<b>Placed</b>
1	Tri-clamp gasket	150 (167*147.2)	EPDM rubber	1	Lid
2	Tri-clamp gasket	51 (64*47.8)	EPDM rubber	2	Sight glass
3	Tri-clamp gasket	38 (50.5*35.3)	EPDM rubber	2	Feeding (up and down)
4	Tri-clamp gasket	25 (50.5*22.5)	EPDM rubber	3	Motor/ Digested slurry outlet
5	Tri-clamp gasket	18 (22*16.2)	EPDM rubber	2	Extra ports on the lid
6	Tri-clamp hinge	150	NG800WH plastic	1	Lid
7	Tri-clamp hinge bolted	51	AISI304 stainless steel	2	Sight glass
8	Tri-clamp hinge bolted	38	AISI304 stainless steel	4	2 Up, 2 Bottom
9	Mini-tri-clamp hinge	18	AISI304 stainless steel	4	Extra ports on the lid
10	Tri-clamp blind	38	AISI316 stainless steel	1	Feeding (up)
11	Mini-tri-clamp blind	18	AISI316 stainless steel	2	Extra ports on the lid



12	Hose connector 6 mm	6*25	AISI316 stainless steel	1	Extra port on the lid (port for gas)
13	Hose connector 12 or 18 mm	12*25 or 18*25	AISI316 stainless steel	1	Extra ports on the lid (port for liq.)
14	Ball valve	9.5 (3/8'')	ASI316/PTFE	2	Discharge/Emptying port
15	Tri-clamp sight glass	51	AISI316 stainless steel/ Borosilicate glass	1	Reactor cylinder
16	Motor holder		AISI316 stainless steel	1	Motor
17	Shaft coupling		Stainless steel	1	Between motor and shaft
18	Shaft gasket	8	EPDM rubber	3	Stirrer
19	Shaft	600	Stainless steel	1	On motor via coupling
20	Propeller	76 (7.9) 3''(5/16'')	Stainless steel	1	Stirrer
21	Sealing for threaded conn		4000T, A2000	1	On ball valve conn

<b>CSTR-10S</b>					
<b>No.</b>	<b>Description</b>	<b>Size (mm)</b>	<b>Material</b>	<b>Qty</b>	<b>Placed</b>
1	Tri-clamp gasket	200 (Diam 217)	EPDM rubber	1	Lid
2	Tri-clamp gasket	51 (64*47.8)	EPDM rubber	3	Sight glass Feeding (up)
3	Tri-clamp gasket	38 (50.5*35.3)	EPDM rubber	1	Feeding (down)
4	Tri-clamp gasket	25 (50.5*22.5)	EPDM rubber	3	Motor/ Digested slurry outlet
5	Tri-clamp gasket	18 (22*16.2)	EPDM rubber	4	Extra ports on the lid
6	Tri-clamp hinge	200	NG800WH plastic	1	Lid
7	Tri-clamp hinge bolted	51	AISI304 stainless steel	2	Reactor cylinder
8	Tri-clamp hinge bolted	38	AISI304 stainless steel	4	2 Up, 2 Bottom
9	Mini-tri-clamp hinge	18	AISI304 stainless steel	4	Extra ports on the lid
10	Tri-clamp blind	51	AISI316	1	Feeding (up)

			stainless steel		
11	Mini-tri-clamp blind	18	AISI316 stainless steel	4	Extra ports on the lid
12	Hose connector 6 mm	6*25	AISI316 stainless steel	1	Extra port on the lid (port for gas)
13	Hose connector 12 or 18 mm	12*25 or 18*25	AISI316 stainless steel	3	Extra ports on the lid (port for liq.)
14	Ball valve	9.5 (3/8")	ASI316/PTFE	2	Discharge/Emptying port
15	Tri-clamp sight glass	51	AISI316 stainless steel/ Borosilicate glass	1	Sight glass
16	Motor holder		AISI316 stainless steel	1	Motor
17	Shaft coupling		Stainless steel	1	Between motor and shaft
18	Shaft gasket	8	EPDM rubber	3	Stirrer
19	Shaft	600	Stainless steel	1	On motor via coupling
20	Propeller	76 (7.9)	Stainless steel	1	Stirrer
21	Sealing for threaded conn		4000T, A2000	1	On ball valve conn

## 11 EQUIPMENT DISPOSAL

Please dispose of your CSTR equipment according to your local waste and recycling regulations for electromechanical devices (regarding the motor) and for the materials specified in chapters 6 and 10.5 (regarding the reactor tank). Keep in mind that it could be your responsibility to decontaminate the equipment from any biological and chemical contamination, to protect from health hazards during recycling of the equipment.

By doing this, you will help to conserve natural and environmental resources and you will ensure that your equipment is recycled in a manner that protects human health. Thank you!