



USER MANUAL

Cap Torque Tester

FSA Series

Contents:

1. Introduction	3
2. Basic Set	3
3. Safety instructions	4
3.1 Main safety rules	4
3.2 Safety rules	5
3.2.1 Transport safety rules	5
3.2.2 Safety rules during start-up and operation	5
3.2.3 Safety rules during conservation	6
4. Mounting device	7
5. Fast start	8
6. Force meter general view	10
7. Keys and indicators	11
8. Technical data	12
9. Preparing the force gauge for operation	13
10. Accumulators exchange (option)	13
11. Turning on the force gauge	14
12. Description of measurement methods	15
12.1 Measuring actual and peak value of a pressure/pull force	15
12.2 Torque characteristics measurement, measurement registration to memory	16
13. Connecting external devices	17
14. User's Menu	19
14.1 Measurement	19
14.1.1 Measurement speed	20
14.1.2 Units	20
14.1.3 Auto-zeroing	22
14.1.4 Comparison with threshold values MIN / OK / MAX	23
14.2 Memory	24
14.2.1 Gathering results	25
14.2.2 Presentation of collected measurements (Statistics)	26
14.2.3 Save, read, erase memory (Statistics)	26
14.3 Configuration	28
14.3.1 Setting serial ports	29
14.3.2 Calibration	30
14.3.3 Information	31
14.3.4 Setting date and time	32
14.3.5 LCD settings	33
14.3.6 Selecting the menu language	34
14.3.7 Printout settings	35
14.3.8 Turning the sound ON/OFF when using the keypad (beep)	36
14.3.9 Automatic power OFF (Auto-OFF)	36
14.3.10 Monitoring the batteries' charge level (Battery)	37
14.3.11 External input	39
14.3.12 Firmware update	39
14.3.13 Defaults	40
15. Maintenance, troubleshooting and repairing minor types of damage	41
16. Force gauge menu diagram	42
Declaration of Conformity	45

1. Introduction

The FSA series testers produced by AXIS Sp. z o.o. are designed for dynamic measuring of torque in laboratories, in manufacturing and quality control applications.

The most popular application is measuring torque during opening a jar.

2. Basic Set

The basic set includes the following elements:

1. Cap torque tester (meter, mounting set, 4 x tie grip),
2. Mounting elements
3. Power supply unit,
4. CD containing user manual
5. Warranty.

3. Safety instructions

3.1 Main safety rules

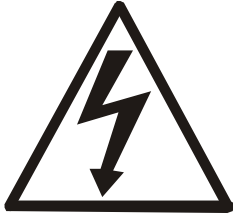

Read carefully the safety instructions included below. Observe these instructions to avoid electrocution or damage to the force gauge itself or other devices connected to the force gauge.

- Repairs and any necessary adjustments may only be conducted by qualified personnel.
- Do not use the force gauge when any part of the enclosure has been removed.
- Do not use the force gauge in potentially explosive atmospheres.
- Do not use the force gauge in areas with a high humidity.
- In the case of suspected damage to the force gauge, turn off the gauge and do not use it until it is examined by a specialised servicing facility.

3.2 Safety rules

3.2.1 Transport safety rules

Torque cap tester should be transported from producer to receiver in original company box.



To transport tester during exploitation original producer case should be used.

3.2.2 Safety rules during start-up and operation

Torque cap tester supplied by producer is a safe device, what was achieved by application of fire protection and elimination of mechanical, chemical, explosive etc threads.

Measurement post that consists of force gauge must be complete and safely mounted by contractor.

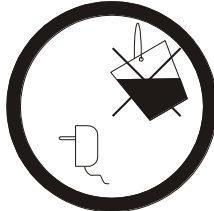
In order to avoid danger we suggest to:

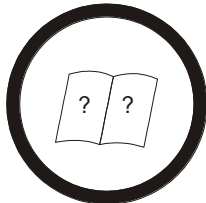
Lp.	Recommendation	Warnings
1	Avoid contact with flood, water or other liquids due to high voltage 230V.	
2	Damaged accumulators handle with care. Use rubber gloves and safety glasses if necessary.	
3	The proper disposal of used force meter.	
4	User manual training.	
5	Periodic monitoring of connections	<div style="border: 1px solid black; padding: 5px; width: fit-content;"> Next control date: </div>

Specific recommendation:



Risk of electric shock due to the use of ~230V 50Hz voltage via external feeder. It is unacceptable to spill the feeder or use it when the enclosure is damaged cause it may cause electric shock.



In order to avoid leakage of electrolyte from accumulators immediate disposal of used accumulators from tester is suggested.

3.2.3 Safety rules during conservation

The device doesn't need conservation except accumulators exchange when used – that happens when after full recharge the force meter working time is shorter more than 20% from the value suggested by producer.



If the device seems to be damaged immediately stop operation.

4. Mounting device

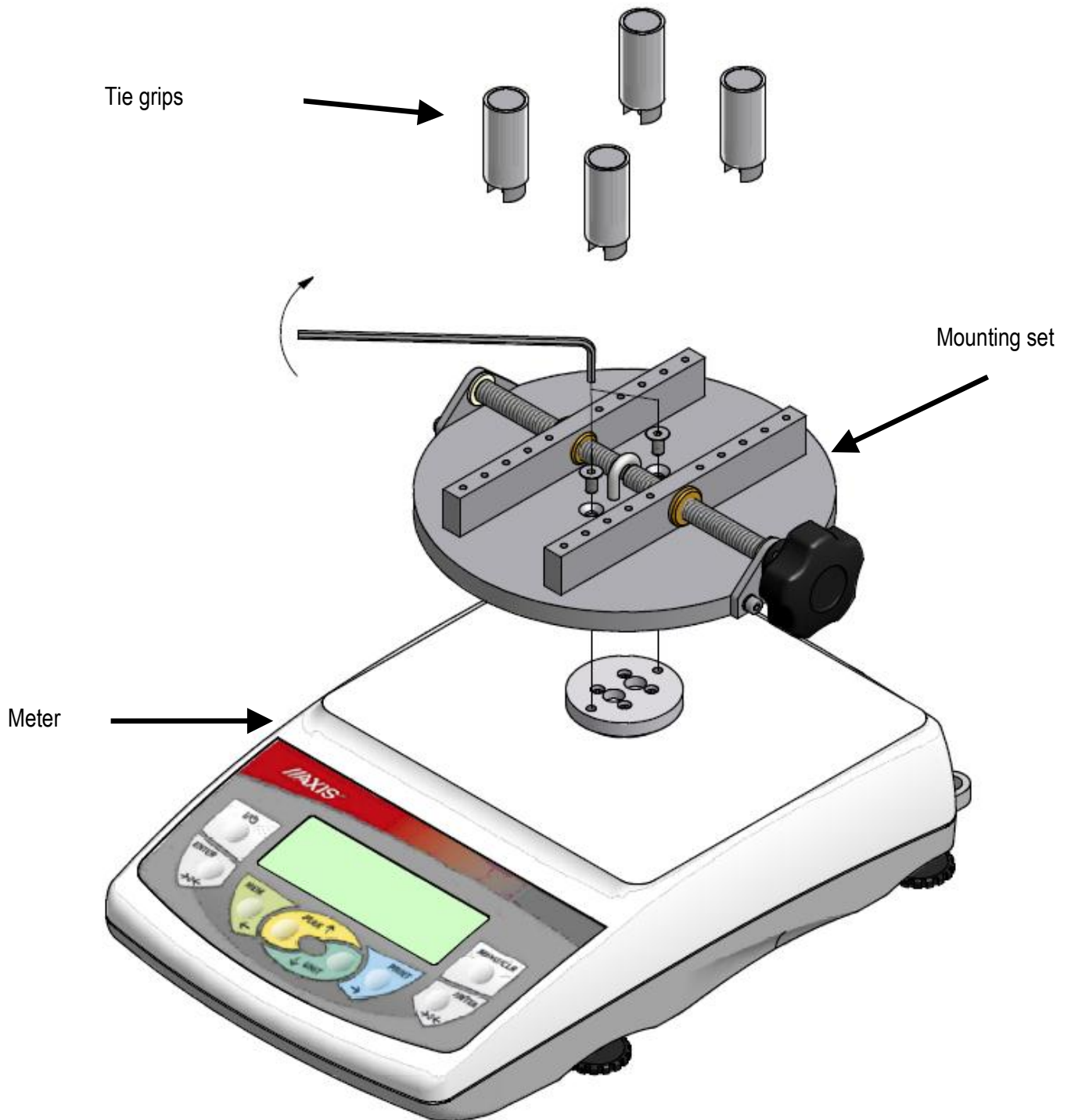

Mount device by using hex key (supplied in the set).

5. Fast start



Situate 4 tie grips on tie rails. Situate object and using knob clamp the tie grips to the investigated object.

Turn on FSA tester by using *//Q* key and leave the device in stationary position. That will enable zeroing, software version displaying and zero indication.

FSA is ready to work after following screen displays:

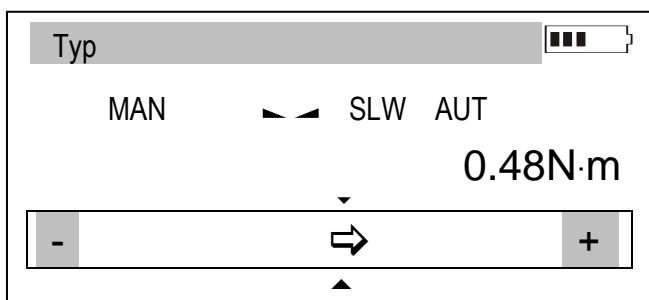
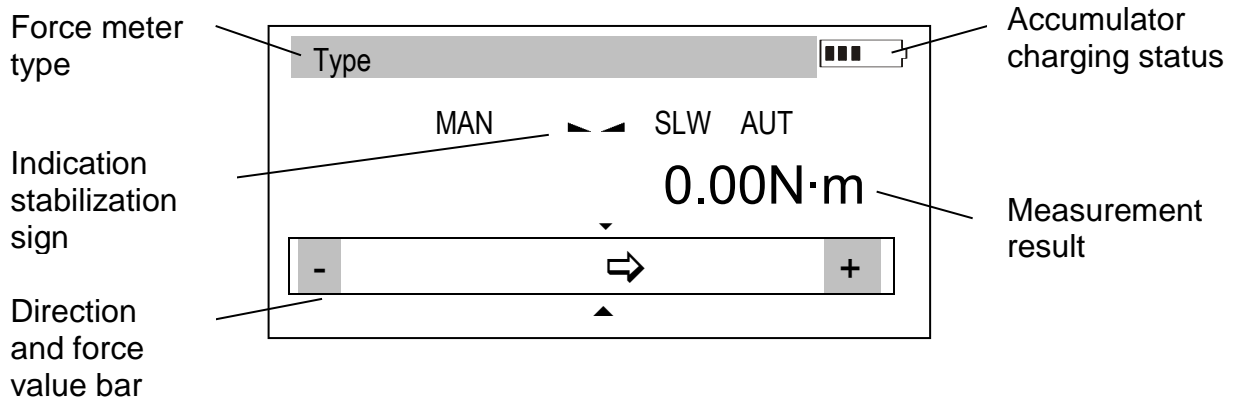

The torque measurement is continuous. Display continuously indicates actual torque value measured by meter. Torque direction is signaled by an arrow in lower part of screen and a sign + or -. Saving actual force indication to memory is done by pressing *MEM* key.

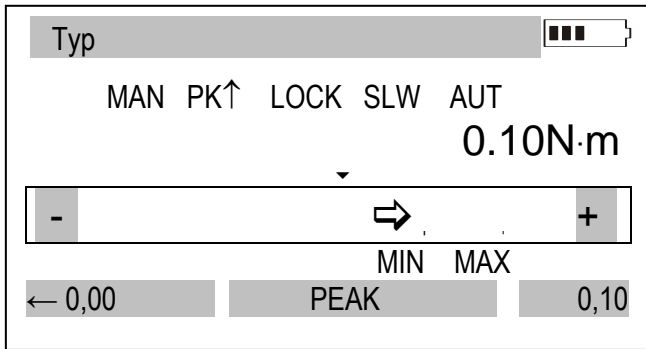

Changing actual torque value indication into peak value measurement is done by pressing *PEAK* key. Indication stabilization sign changes into *LOCK* sign and force meter changes mode into one-direction. Pressing again *PEAK* key will change recorded force direction (*PK↑*, *PK↓*), zeroing is done by $\rightarrow 0 \leftarrow$ key.

Attention:

Dynamical torque measurement should be carried out by saving to memory series of measurements with given sample time, then display force characteristics and statistical results (14.3 *Memory*).

6. Force meter general view

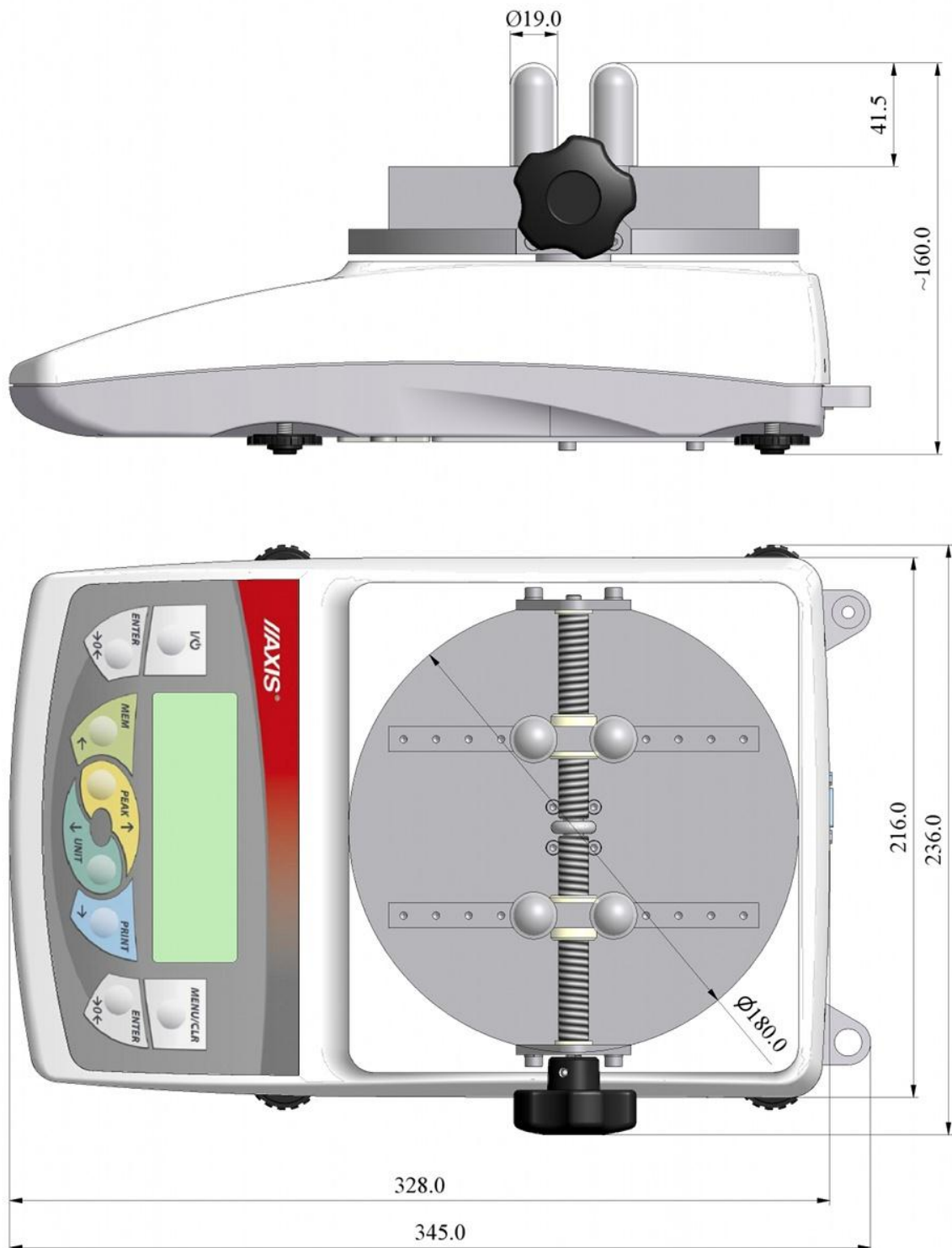

7. Keys and indicators

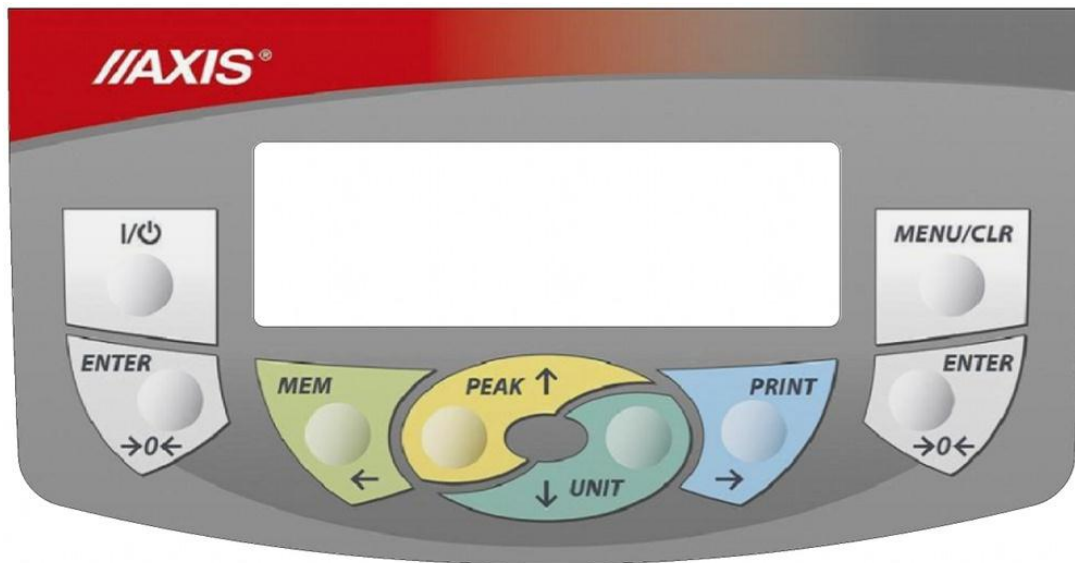

I/Q - ON / OFF key (standby),

Navigation keys:

- ↑ - Move cursor up or increase the digit marked by the cursor,
- ↓ - Move cursor down or decrease the digit marked by the cursor,
- - Move to the next menu level or display the next option,
- ← - Move to the previous menu level or display the previous option,

ENTER - Confirm the entered parameter or select a highlighted option.

Function Keys:

- MENU/CLR** - Meter function menu (diagram menu - chapter 18),
- PEAK** - Maximum value measurement,
- MEM** - Save the result to the memory, *after measurements* – results exposure (Statistics),
- PRINT** - Print result (transmission via RS-232C connector),
- 0←** - Force meter indications zeroing,
- UNIT** - Unit change.

Status indicators:

- MIN/OK/MAX** - Indications below MIN; in range MIN÷MAX; above MAX
- MAN/ACQ** - Manual/automatic measurements mode
- ▴/LOCK** - Indicates that the weighing result has stabilised,
- PK↑ / PK↓** - Direction of measured torque,
- SLW/FST** - Slow/fast measurement mode,
- AUT** - Autozeroing on.

Note:

Numbers are entered using the navigation keys. First, the cursor is placed in the right digit position.

8. Technical data

Type	FSA2	FSA5	FSA10
Maximal torque (Max)	2Nm	5Nm	10Nm
Readout unit (d)	0,001Nm	0,001Nm	0,01Nm
Unit	Nm, N*cm, kgf*m, gf*m, lbf*in		
Working temperature	-10 ÷ 40°C		
Speed of measurements	Regulated max 1000 measurements/s		
Internal memory	8x800 measurements		
Interface	RS-232C		
Supporting software	-		
Display	LCD graphical		
Measurement options	maximal value measurement, serial measurement, dynamical measurement (graph))		
Supply	Feeder ~230V 50Hz / 12V 1,2A		
Range of samples diameters	from Ø20mm to Ø180mm		
Dimensions	345x236x160mm		
Weight	5,1kg		
Conditions	-10 ÷ 40°C, humidity <80%		

9. Preparing the force gauge for operation



If the FSA has been transported from an area with low temperature to an area with a higher temperature, e.g. during winter, water may condensate on the gauge's enclosure. In such a case, do not turn on the gauge's power supply, as it may lead to damage to the gauge or improper operation. Before turning on the gauge, leave it for 1 hour to acclimatise.

10. Accumulators exchange (option)

If during exploitation time working time of fully charged accumulators shortens to 20% of the nominal value (under 4h), replace them with new ones.

In order to exchange accumulators open the cover by unscrewing 2 bolts and put new accumulators as indicated at the bottom of the housing (correct polarization).

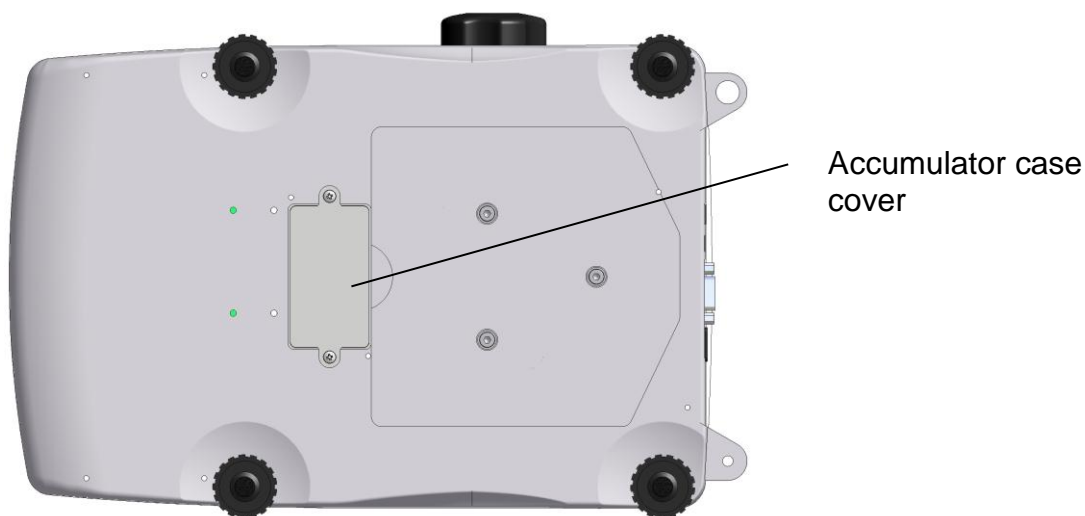

11. Turning on the force gauge

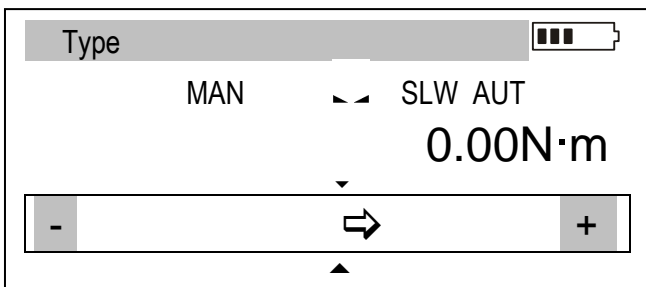
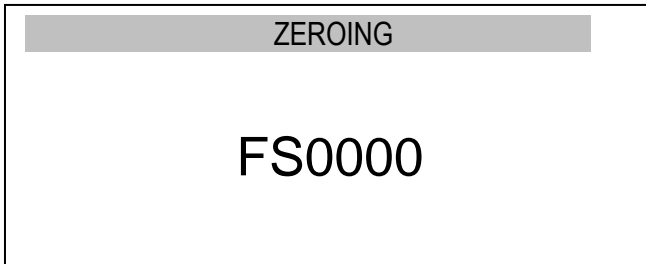

Put the tester on stable ground.

Plug the tester's power supply unit to a ~230 V/50 Hz socket and connect the power supply unit's plug to the gauge's 12 V socket.

Turn on the FSA by pressing the I/Q key.

The gauge automatically tests the electronic subassemblies and then resets. During this operation, the gauge should remain stationary and its sensor should not be affected by any forces.

After the resetting has been successfully completed, the gauge indicates zero.

Unsuccessful resetting is signalled by an appropriate message.

Note:

If the batteries are low, leave the tester's external power supply unit ON until they are fully recharged. The batteries' charge level is signalled by an indicator in the upper section of the display.

12. Description of measurement methods

The FSA tester can be used to measure pressure and pull forces. In addition, when mounted properly, it can be used as suspension scales to measure the mass.

12.1 Measuring actual and peak value of a pressure/pull force

The zeroing process starts automatically after turning on the device or by pressing the $\rightarrow 0 \leftarrow$ key.

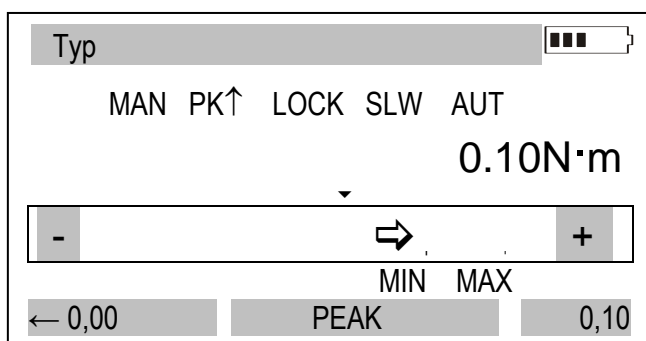
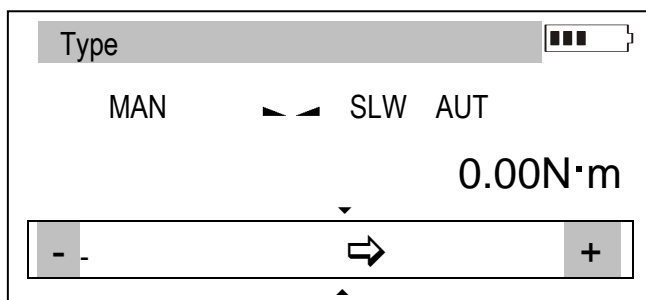
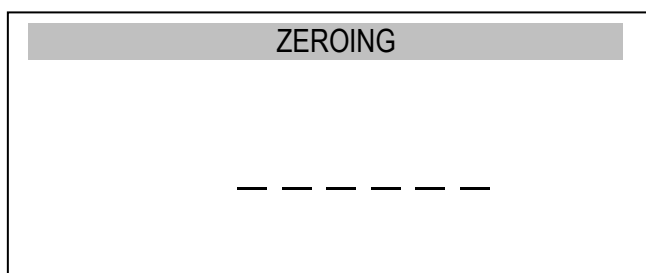

To perform the measurement, indicate the force direction using an arrow in the display's lower bar section and "+" or "-" symbol.

To change the measurement from the actual value (continuous measurement) to the maximum value (peak measurement), use the *PEAK* key – stabilization indicator is replaced by *LOCK* indicator. Pressing again *PEAK* button will change direction of the measured force ($PK\uparrow$, $PK\downarrow$), zeroing by using $\rightarrow 0 \leftarrow$ key.

When measuring maximum value, at the bottom of the screen appears a bar showing actual torque value and maximum torque value for other direction if it was measured before - otherwise 0,00 value will indicate.

12.2 Torque characteristics measurement, measurement registration to memory

In order to enable changing torque measurement and to create results visualizations (graphs or histograms), FSA cap tester is equipped with actual results buffer memory (RAM) and EEPROM memory. Detailed description of available options can be found in 15 chapter.

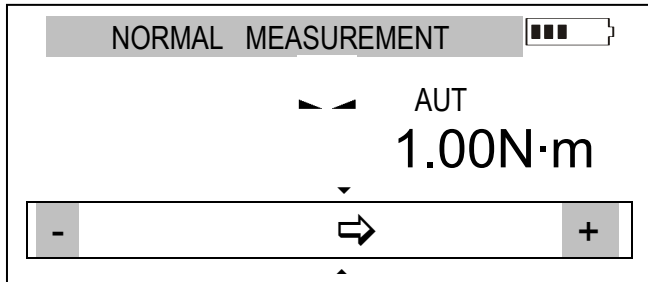

MEM

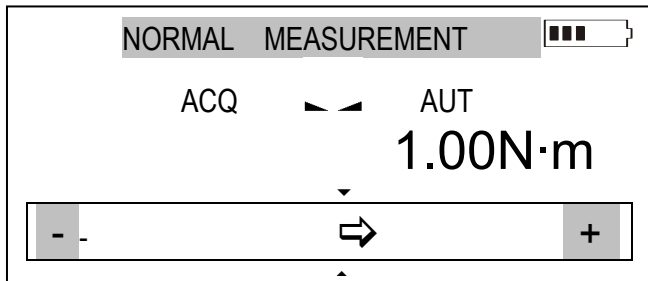
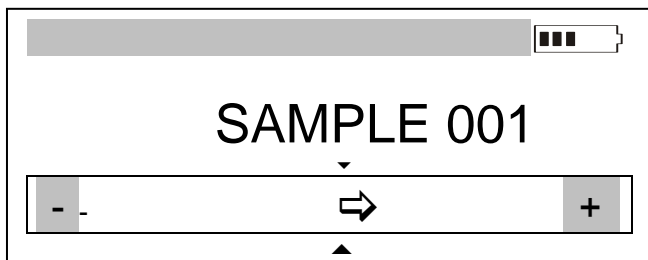

MEM

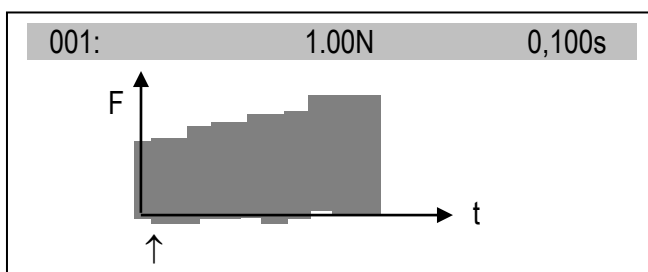
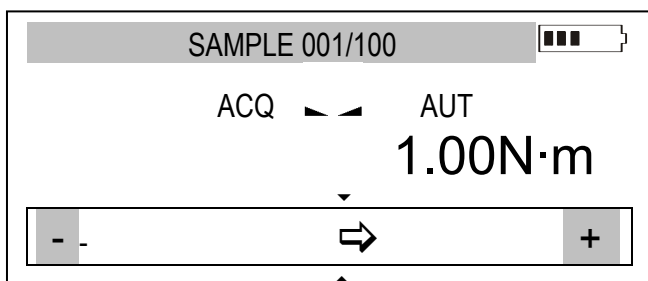

After pressing MEM key results are stored in buffer memory. Quantity of result in a 1 serie is set in *Memory/Setting/Quantity* .

If indicator *MAN* (manual mode) is displayed, after pressing *MEM* key single measurement is stored.

When ACQ indication is turned on, *MEM* key starts storing measurements in equal time intervals.

During storing measurements successive sample numbers are displayed and total quantity.

During measurement storing, numbers of samples and total sum of samples are displayed.

After storing all samples a graph is displayed.

ENTER – returns to force indications, *MEM* – *Statistics* results displaying. *Statistics* option is used for obligatory storing or deleting actual results (next measurement is possible only after deleting).

UNIT/CLEAR enables quick exit from *Statistics* option.

13. Connecting external devices

The force gauge is equipped with a socket for an external power supply unit, RS232C (RJ joint) and USB interface.

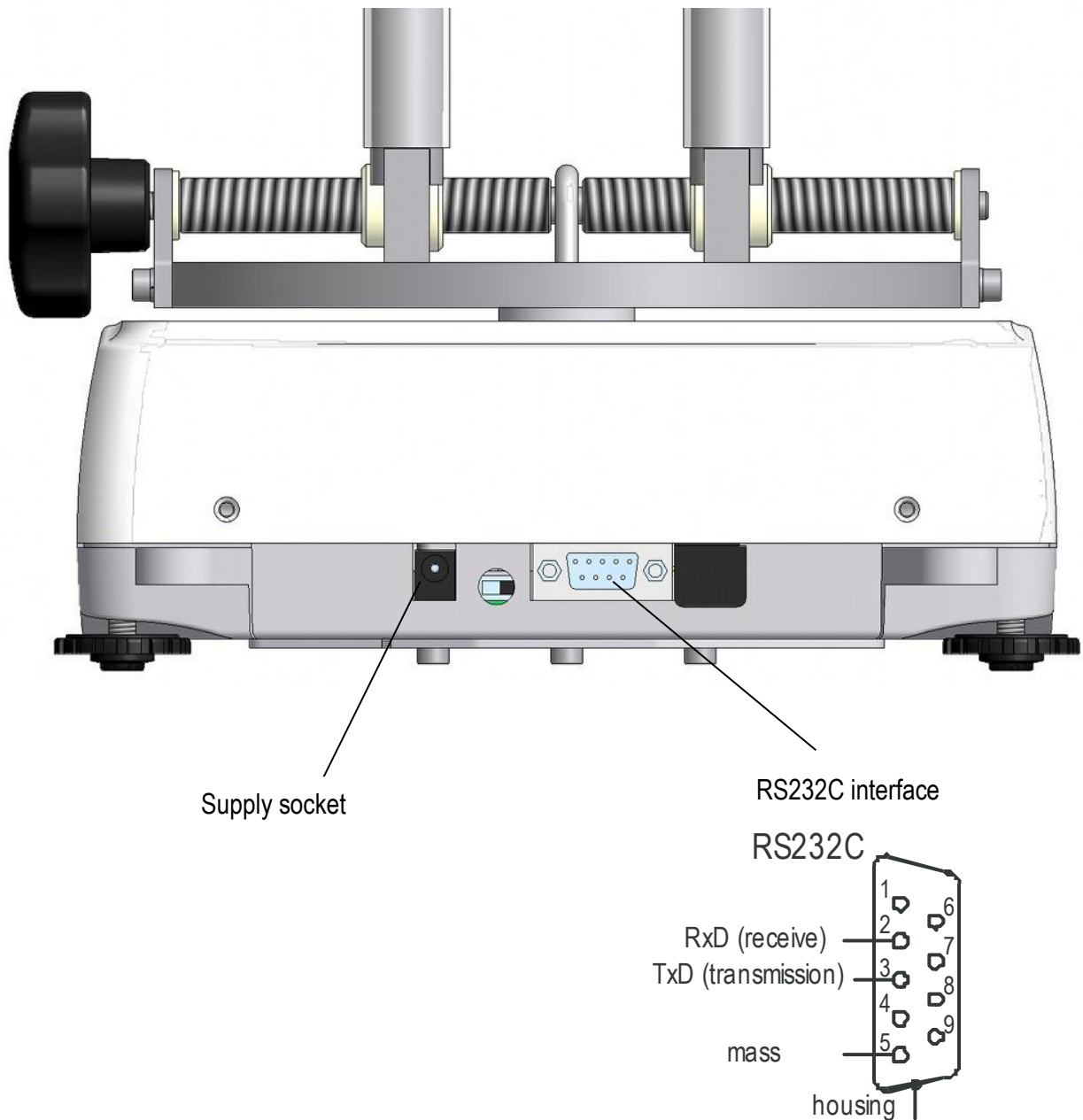

Description of the data transmission (RS232C) protocol when working with a computer (*LonG*):

The force gauge transmits the result as follows (8 bits, 1 stop, no parity, 115200 bps):

Computer→Gauge: initiating signal S I C R L F (53 h 49 h 0Dh 0 Ah),

Gauge→Computer: gauge indication according to the following format (16 bytes):

Description of individual bytes:

byte	1	- “-“ or space
byte	2	- space
byte	3÷4	- digit or space
byte	5÷9	- digit, comma or space
byte	10	- digit
byte	11	- space
byte	12	- k, l, c, p or space
byte	13	- g, b, t, c or %
byte	14	- space
byte	15	- CR
byte	16	- LF

14. User's Menu

The User's Menu includes all functions and options necessary to operate the gauge or extend its functionalities.

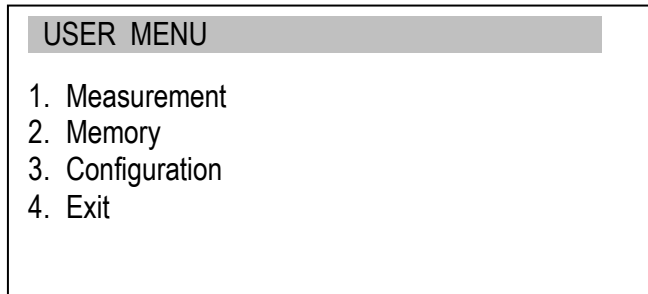

To use the options of the USER's MENU, use the *MENU* key. Move the cursor to the desired option and press *ENTER*.

The menu includes:

1. *Measurement* – measurement settings,
2. *Memory* – data readout and saving options,
3. *Configuration* – calibration and other options,
4. *Exit*.

14.1 Measurement

This selection includes the following functions to effectively assist you with the measurement:

- measurement speed in automatic mode,
- measurement unit choice,
- automatic zeroing,
- comparison with two threshold values (*MIN / MAX*),
- measured force direction change (accepted as plus +),
- automatic saving PEAK function result after the force is gone.

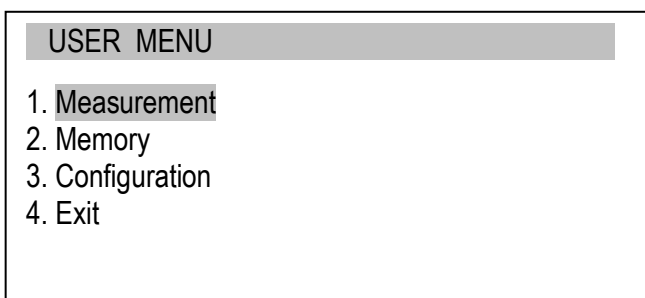

Move the cursor to *Measurement* and press *ENTER*.

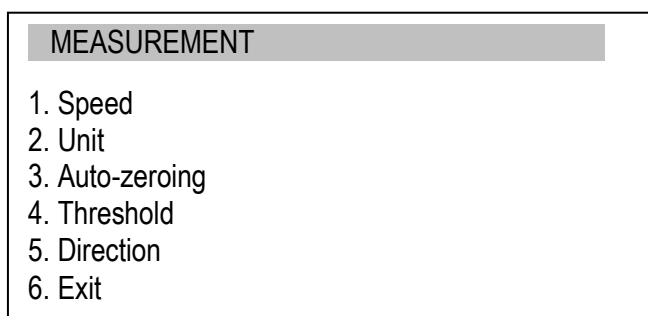

Move the cursor to the desired application and press *ENTER*.

14.1.1 Measurement speed

To obtain clear measurement results, it is recommended to adjust the speed of measurement to the dynamic properties of the measured object.

The image displays three sequential screenshots of a device's menu system, illustrating the steps to adjust measurement speed:

- USER MENU**
 - 1. Measurement
 - 2. Memory
 - 3. Configuration
 - 4. Exit
- MEASUREMENT**
 - 1. Speed
 - 2. Unit
 - 3. Auto-zeroing
 - 4. Threshold
 - 5. Direction
 - 6. Exit
- SPEED**
 - 1. Smp.time: 0.001 s
 - 2. Exit

Choose *Smp.time* and press *ENTER* to change sample time value using navigation keys.

14.1.2 Units

Torque units:

- newton-metre (N·m) – torque basic unit,
- newton-centimetre (N·cm): $1\text{N}\cdot\text{m} = 100\text{N}\cdot\text{cm}$,
- kilogram-metre (kg·fm): $1\text{N}\cdot\text{m} = 0,1020\text{kgf}\cdot\text{m}$,
- gram-force-metre (gf·m) : $1\text{N}\cdot\text{m} = 1020\text{gf}\cdot\text{m}$,
- pound-force-inch (lbf·in): $1\text{N}\cdot\text{m} = 8.85\text{lbf}\cdot\text{in}$.

To change the units, press the *UNIT/CLEAR* or *MENU* key several times.

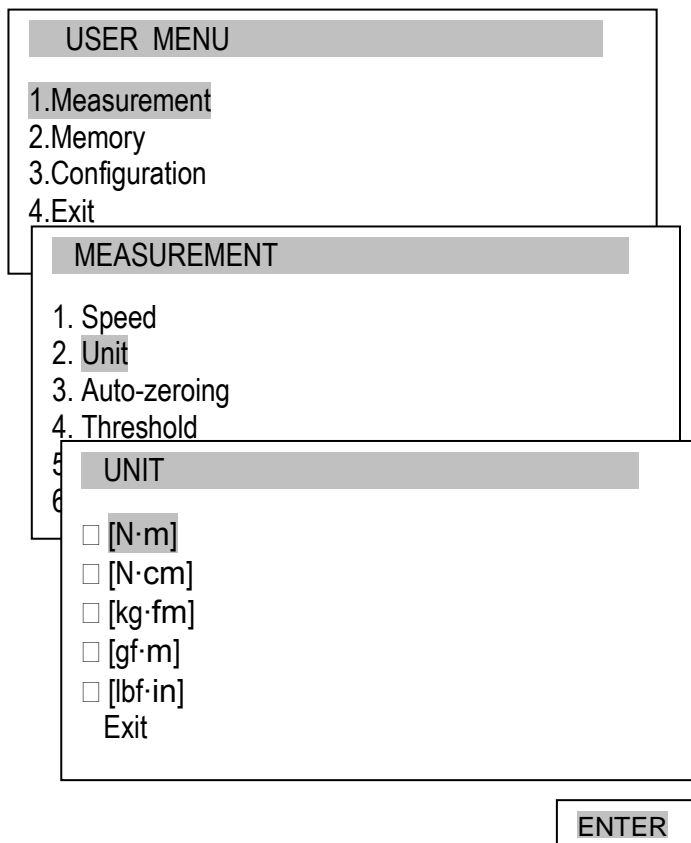

Press the *MENU* key, move the cursor to *Unit* and press *ENTER*.

Move the cursor to the desired unit and press *ENTER*.

14.1.3 Auto-zeroing

When activated, this option automatically maintains zero indications on the device, if the device's sensor is not affected by any external force or if the zero indication was produced by pressing the $\rightarrow 0 \leftarrow$ key. The range of values (calculated in the gauge's reading graduation near zero) subject to the reset must be entered under the *Range* option (2 digits).

USER MENU	
1.Measurement	
2.Memory	
3.Configuration	
4.Exit	
MEASUREMENT	
1. Speed	
2. Unit	
3. Auto-zeroing	
4. Threshold	
5. Direction	
6. Exit	

Use the navigation keys and *ENTER* to select *Status* and one of the following options:

- *ON* – auto-zeroing ON,
- *OFF* – auto-zeroing OFF.

Next, select *Range* and use \uparrow , \downarrow , \rightarrow , \leftarrow and *ENTER* to enter the auto-reset range (in reading graduation).

AUTO-ZEROING	
1. Status	<ON>
2. Range	2 d
3. Art.zero	<OFF><SET>
3. Exit	

↑	↓	ENTER
---	---	-------

AUTO-ZEROING	
1. Status	<ON> <OFF>
2. Range	2 d
3. Art.zero	
4. Exit	

←	→	ENTER
---	---	-------

Additional option *Art.zero* enables to set device start zero to the value indicated before entering the *MENU*.

14.1.4 Comparison with threshold values MIN / OK / MAX

This selection includes the following functions to effectively assist you with the measurement:

- memory operations and data analysis,
- comparison with two threshold values (*MIN / MAX*).

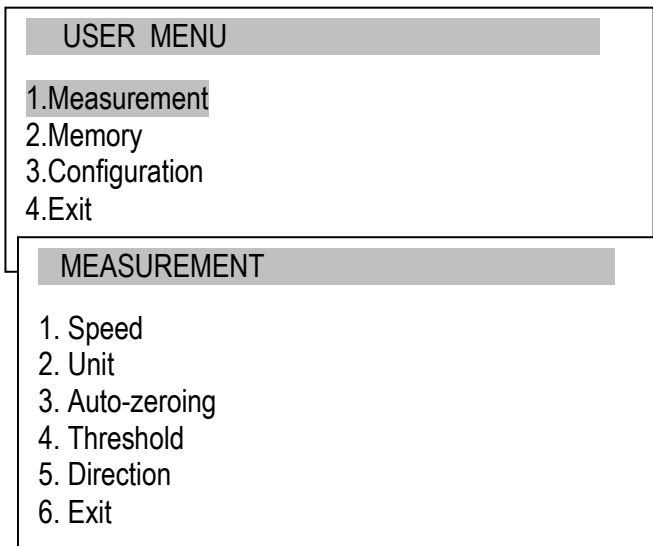

Move the cursor to *Applications* and press *ENTER*.

Move the cursor to *Threshold* and press *ENTER*.

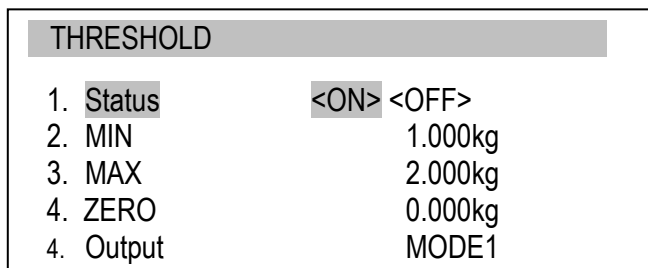

Activate the comparison by setting *Status* to *ON*:

- enter the *MIN* value – lower threshold,
- enter the *MAX* value – upper threshold,
- enter *ZERO* – zero signalling threshold.

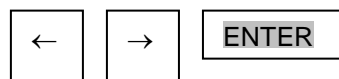

Select the option for *OUTPUT* and sound signalling (*Buzzer*):

- *MODE1* – short signal upon exceeding *MIN*, long signal upon exceeding *MAX*,
- *MODE2* – interrupted signal below *MIN*, above *MAX* – continuous signal, for *OK* – no signal.

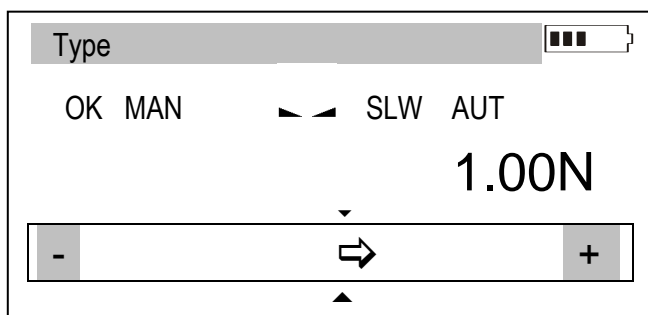

Exit the menu, start the measurement and observe the *MIN*, *OK* and *MAX* indicators on the gauge's display.

14.2 Memory

During measurements in automatic mode results are saved in volatile memory (RAM – erasing data after supply off). Saving, readout, erasing data in EEPROM and resetting volatile memory (RAM) is done by options in lower part of *Statistics* function screen. It is possible to view results on force meter (chart, histogram, table).

Memory option enables to:

- select gathering results mode,
- exposure of gathered measurements, storing , readout, deleting memory (*Statistics*),
- exit.

14.2.1 Gathering results

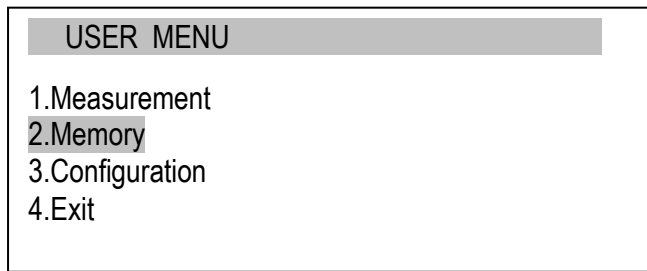

Move the cursor to *Memory* and press *ENTER*.

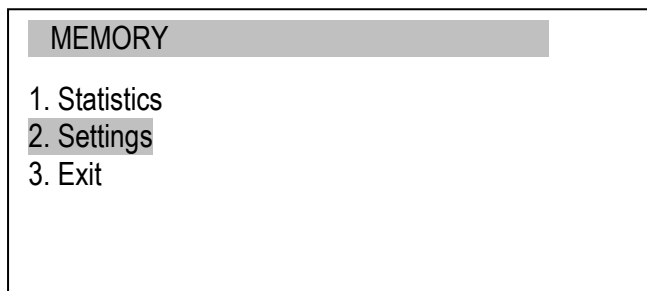

Move the cursor to *Settings* and press *ENTER*.

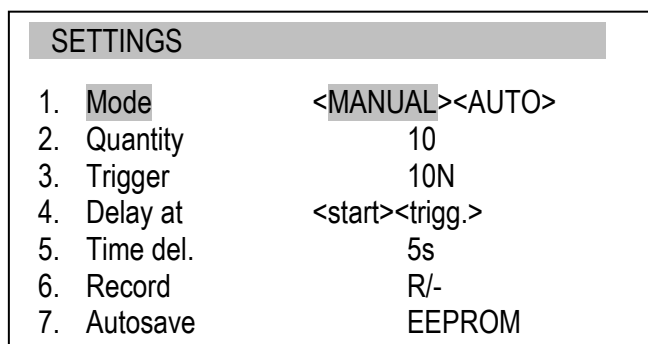

Setting the mode for collecting data:

- *MANUAL* – each time after *MEM* is pressed,

- *AUTO* – automatically at specified intervals.

Insert quantity of samples (max 100)

After choosing *Manual* mode user should specify whether he wants to save the time of each measurement (*R/D&T* option).

In *Autosave* option user can choose the place of autosaving results (*EEPROM*).

In automatic mode it is possible to set result storing delay time (*Time del.*; during countdown *TRG* indicator blinks) and trigger level (*Trigger*) – that is the torque level above which registration process begins.

In automatic mode (*AUTO*) it is also possible to set measurements recording delay (*Time del.* ; during countdown *TRG* indicator blinks) and trigger level (*Trigger*) – the force value above which registration process begins.

To start the collection of measurements, exit the menu and press *MEM* several times or press *MEM* for automatic save. When in the automatic save mode, press and hold *MEM* to go to the data save menu.

After collecting measurements they are exposed (*Statistics*).

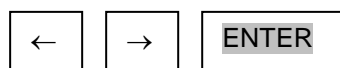

14.2.2 Presentation of collected measurements (Statistics)

The *Statistics* option allows for the following forms of presentation of the collected data:

<PRINT> – transmission to a printer,

<HISTOGRAM> – bar graph,

<GRAPH> – graph with a time axis.

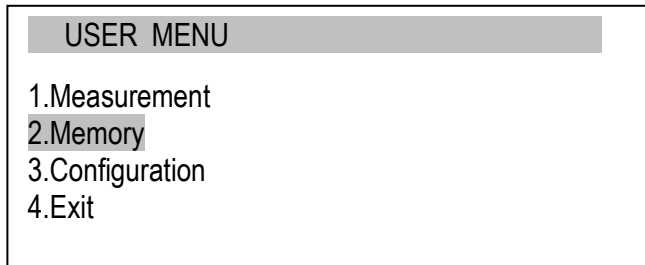

Move the cursor to *Memory* and press *ENTER*.

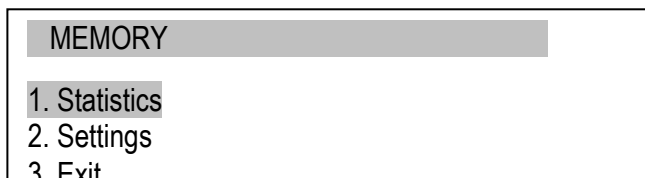

Move the cursor to *Statistics* and press *ENTER*.

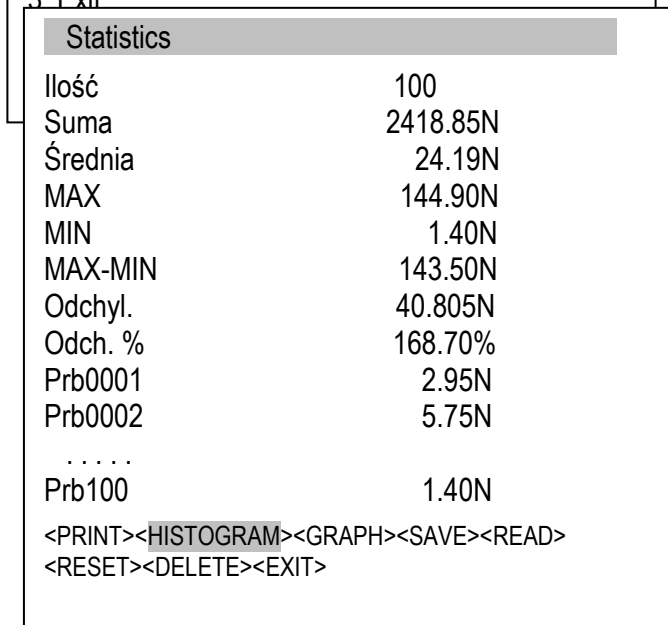

Select one of the options from the lower menu bar:

- *PRINT* – transmission to a printer,

- *HISTOGRAM* – bar graph,

- *GRAPH* – graph with a time axis.

...

- *RESET* – erases the entire memory,

- *DELETE* – deletes a selected memory file.

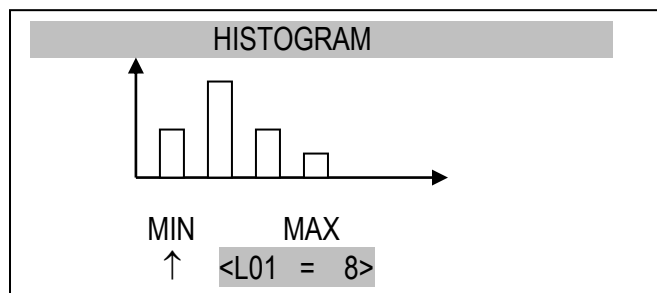

Indicators <L... =..> provide the size of the bar indicated by the ↑ arrow.

To move the arrow (scroll the graph), use the ← and → keys.

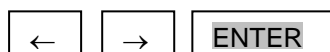

14.2.3 Save, read, erase memory (*Statistics*)

The *Statistics* option allows for the following:

- < *SAVE* > – saves the data currently presented,
- < *READ* > – reads a file from the memory,
- < *RESET* > – erases the data currently presented,
- < *DELETE* > – delete selected data file.

These options show up in the bottom bar (change option using ← or → keys).

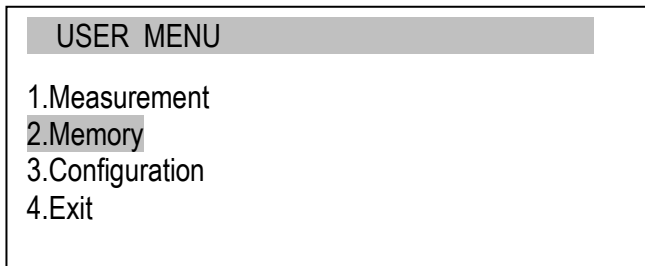

In order to choose saving location move the cursor to *Memory* and press *ENTER*.

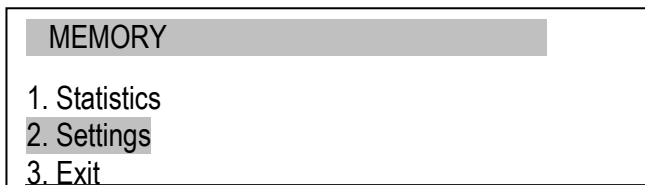

Move the cursor to *Settings* and press *ENTER*. Choose *Mode*. In *Auto* mode results are saved to *RAM* memory. In *Manual* mode saving to *RAM* or *EEPROM*.

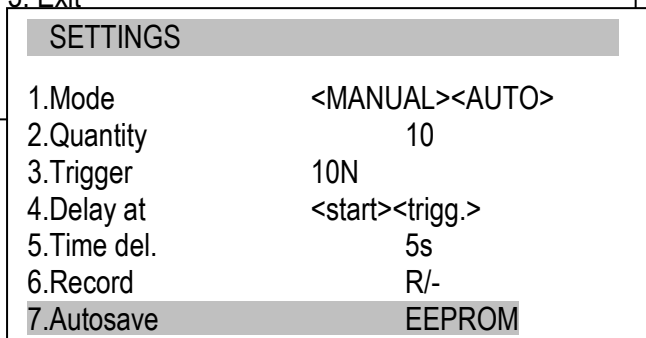

14.3 Configuration

This selection includes all options for setting the gauge's modes of operation.

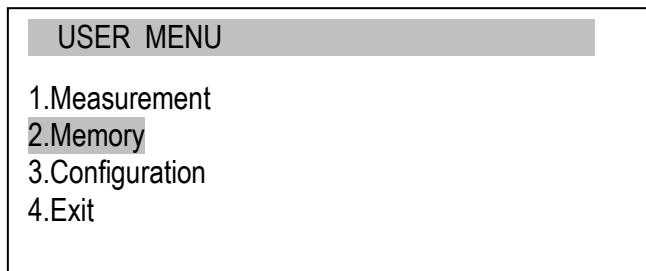

Move the cursor to *Configuration* and press *ENTER*.

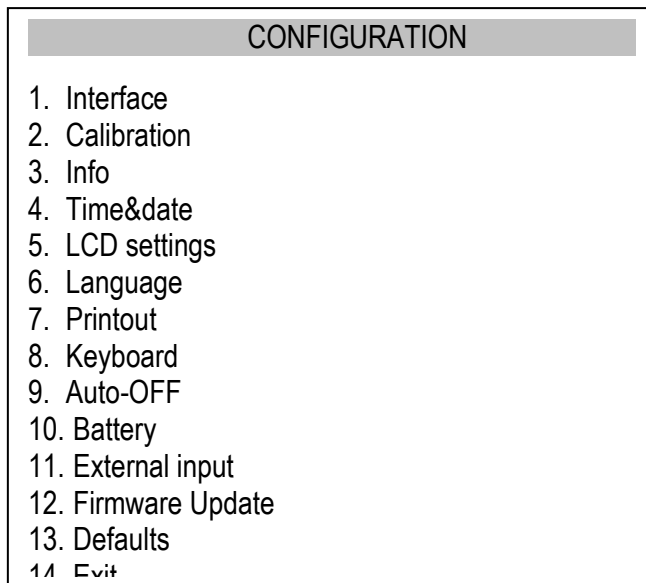

Move the cursor to the desired option and press *ENTER*.

ENTER

14.3.1 Setting serial ports

The parameters of the serial connector must be suitable for the device receiving the signal.

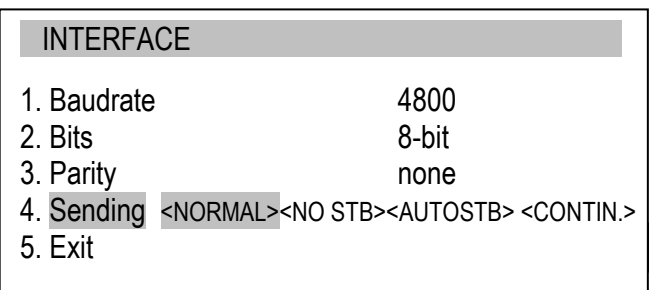
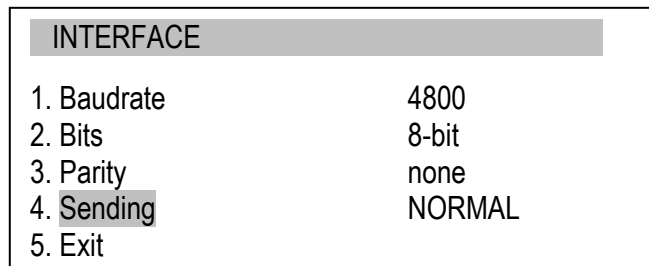
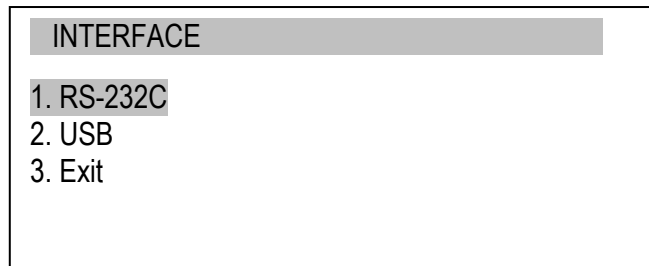
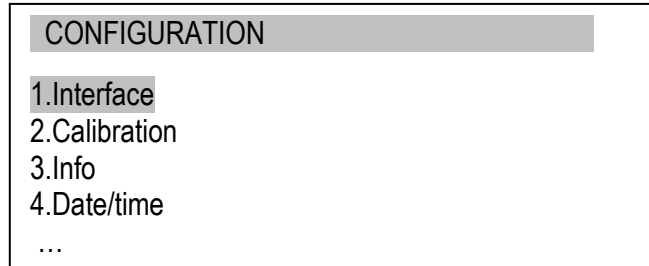
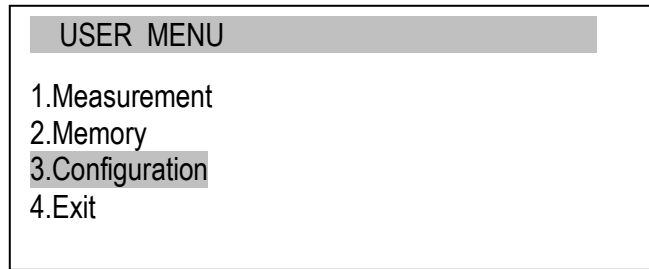

Parameters to be set:

- *Baudrate* – transmission and receiving rate (4,800 ÷ 115,200 bps),
- *Bits* – number of bits which constitute a character (7 or 8 bits),
- *Parity* – control of parity (no control, even – confirmation of parity, or odd – confirmation of odd parity),
- *Sending* – transmission method during measurement:
 - *NORMAL* – after using the *PRINT* key, with stable result,
 - *NOSTB* – after using the *PRINT* key, irrespectively of the result stability,
 - *AUTOSTB* – automatically after the result has stabilised,
 - *REMOVE* – automatically after unload (under 10d or zero signalization threshold) previous stable result is send; if *PEAK* option is on, after unloading zeroing of indications is carried out,
 - *CONTIN.* – continuous transmission, approx. every 0.1 s.



When the force meter is equipped with two serial interfaces (RS232C and optional USB) in submenu *Interface* two options are available *RS232C* and *USB*. After choosing proper port all settings are done the same way as above.

14.3.2 Calibration

Entrance to calibration is secured by PIN password. Calibration should be executed by AXIS personnel.

USER MENU	
1.Measurement	
2.Memory	
3.Configuration	
4.Exit	

↑	↓	ENTER
---	---	-------

Reset the device without load using the →0← key.

Use the navigation keys and *ENTER* to select *Configuration* and then *Calibration*.

CALIBRATION	
1. Calibration - START	
2. Calibration mode	Nm
3. Torque	2.00Nm
4. Gravitational acc.	9,81416m/s ²
5. Arm's length	0,500m
6. Correction	
7. Load cell	
8. Factory calibration	
9. PIN	
10. Exit	

↑	↓	ENTER
---	---	-------

Depending on the arm choose *Torque* and *Arm's length* options.. The <...> option allows for entering any value.

Enter the gravitational acceleration to correctly convert mass (kg) into force (N).

If the exact “g” value is not known, enter the parameters of the geographical location (latitude and above mean sea level). The “g” value will be calculated automatically.

Apply the standard of mass to the gauge.

CALIBRATION	
1. Calibration - START	
2. Calibration mode	Nm
3. Torque	2.00Nm
4. Gravitational acc.	9,81416m/s ²
5. Arm's length	0,500m
6. Correction	
7. Load cell	

↑	↓	ENTER
---	---	-------

Use the navigation keys and *ENTER* to select *Calibration* and wait until the calibration process is completed.

Correction option enables changing torque indications with inscribed value.

Factory calibration option enables to return to factory settings.

14.3.3 Information

Option gives basic information about the device.

USER MENU
1.Measurement
2.Memory
3.Configuration
4.Exit

CONFIGURATION
1.Interface
2.Calibration
3.Info
4.Date/time
...

INFO
MODEL
MAX
SOFT
DATE
S/N
AXIS Sp. z o.o.

Available information:

- device type (*Model*)
- measurement range (*MAX*)
- internal software version (*SOFT*)
- serial number (*S/N*)
- production date (*DATE*)
- memory card type (*Card*)
- producer name

14.3.4 Setting date and time

This option is used for entering the current date and time. Access to this setting is secured by the *PIN* code.

USER MENU	
1.	Measurement
2.	Memory
3.	Configuration
4.	Exit

CONFIGURATION	
1.	Interface
2.	Calibration
3.	Info
4.	Date/time
...	

TIME&DATE	
1. Time	10:00:00
2. Date	2011-01-11
3. PIN	0
4. Format	<YYYY-MM-DD><MM- DD- YYYY> <DD-MM-YYYY>
5.	Exit



Use the navigation keys and *ENTER* to select *Date and time*. If a *PIN* has already been entered (other than 0), after selecting *Time* or *Date*, the cursor will move to the *PIN* option, where a correct 4-digit *PIN* has to be entered. To enter the correct digits, use the ↑, ↓, →, ← keys and *ENTER*.

To enter a new code (*NEW*), select the *PIN* option. When entering a new code, type in the same number twice (message: *REP.*).

The *FORMAT* option allows for the selection of the date format on print-outs.

14.3.5 LCD settings

This option adjusts the gauge's display to external lighting conditions.

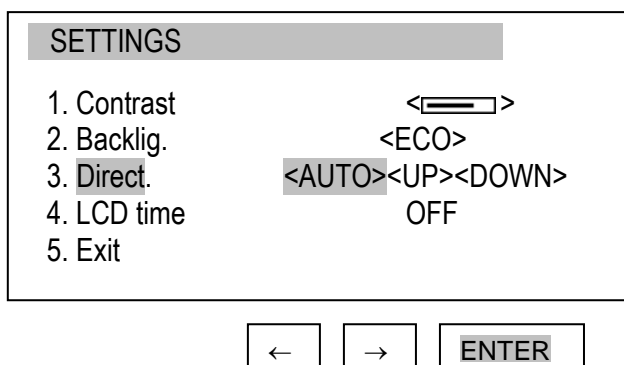
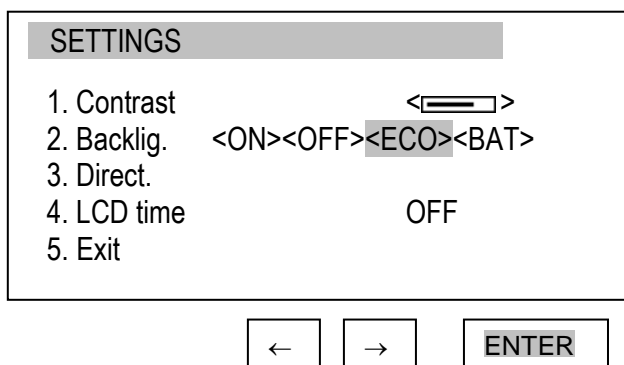
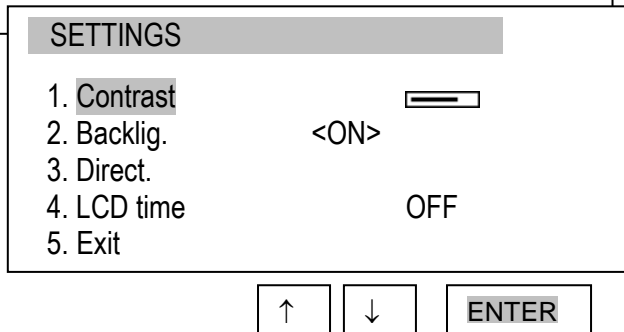
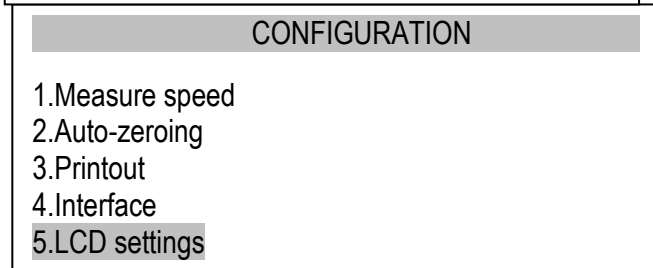
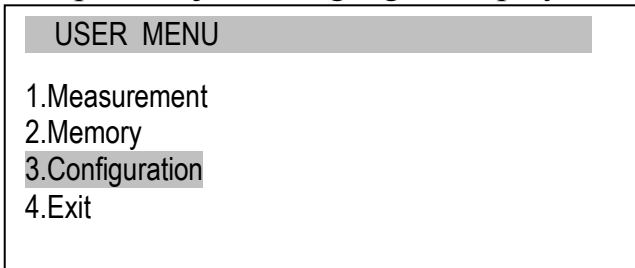

Use the navigation keys and *ENTER* to select *LCD settings*. Next, use *→*, *←* and *ENTER* to set the contrast at which the display is best legible.

When setting *Backlig.* (backlighting), select one of the following options:

- *OFF* – backlighting OFF,
- *ON* – backlighting continuously ON,
- *ECO* – to backlight, use the *BACKLIGHT* key,
- *BAT* – backlighting is turned off after 30 seconds to save the batteries.

The *DIRECT.* (direction) option is used for selecting the display's direction:

- *AUTO* – automatic rotation of the displayed image,
- *UP* – standard direction,
- *DOWN* – inverted image.

The *LCD TIME* option displays the date and time during measurement in the display's upper bar.

14.3.6 Selecting the menu language

Three menu languages are available:

- <PL> – Polish,
- <ENG> – English,
- <DE> – German,
- <ESP> - Spanish.

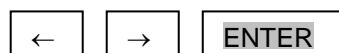
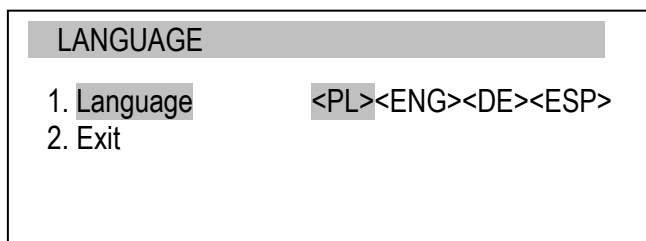
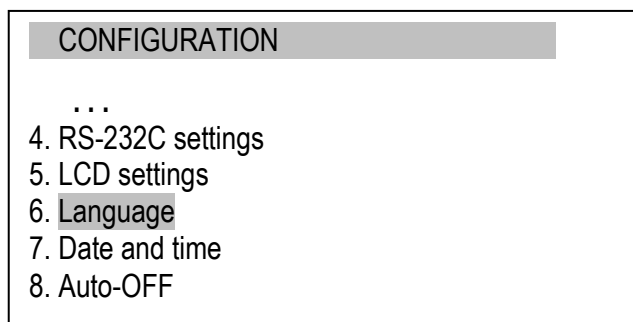
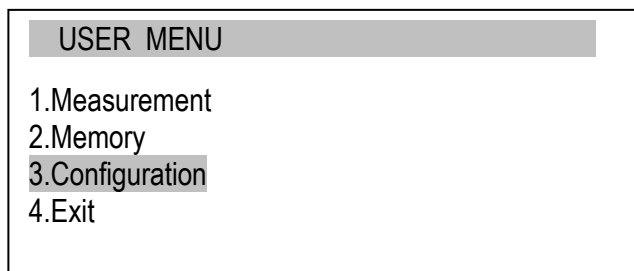

Use the navigation keys and *ENTER* to select *Language*. To select one of the available menu languages, use the →, ← keys and *ENTER*.

To enter a new code (*NEW*), select the *PIN* option. When entering a new code, type in the same number twice (message: *REP.*).

14.3.7 Printout settings

According to the requirements of GLP procedures, it is possible to use an external printer to produce print-outs from the gauge including text information.

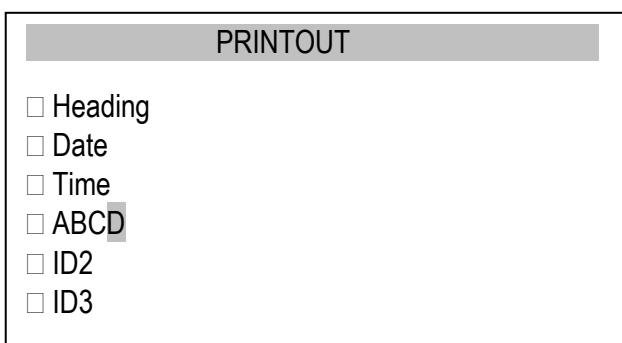
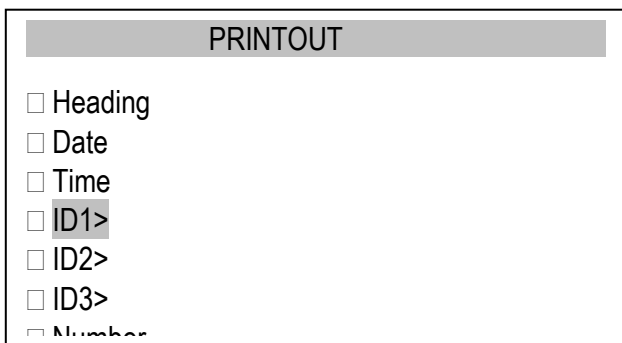
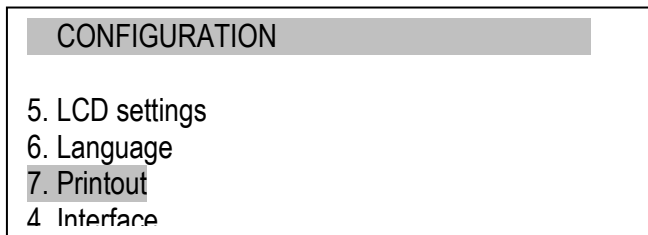
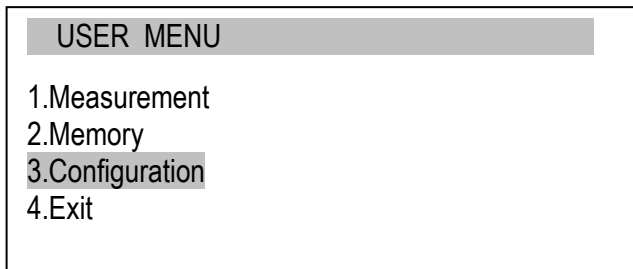

Use the navigation keys and *ENTER* to select *Printout* and the suitable print components.

ID1, ID2, ID2 – text strings (up to 20 characters) forming the lines of the print-out, entered using the gauge’s navigation keys (starting from →).

To enter the characters, select *ID* using *ENTER* and press →. The characters are entered using the navigation keys ↑ and ↓. To move the cursor to the consecutive positions, use ← and →. To confirm the entered string, press *ENTER*. To delete a character, enter space

14.3.8 Turning the sound ON/OFF when using the keypad (beep)

This options turns ON or OFF the sound signalling that a key on the keypad has been pressed. When the sound is turned on, the user usually does not apply excessive force when pushing the keys.

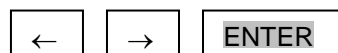
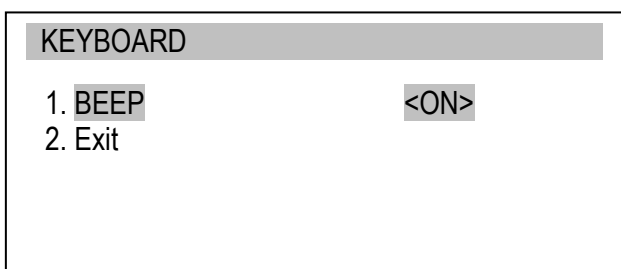
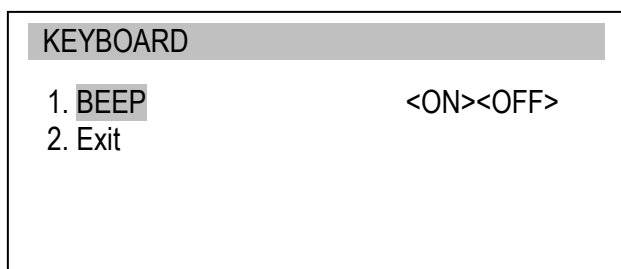
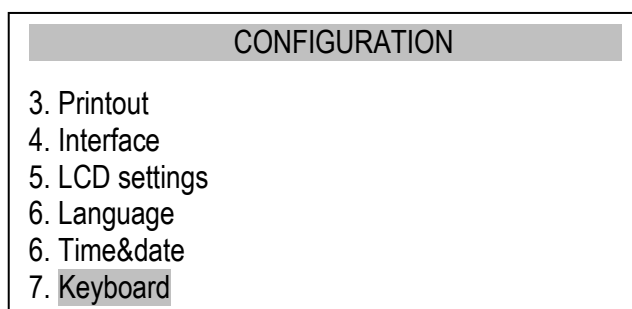
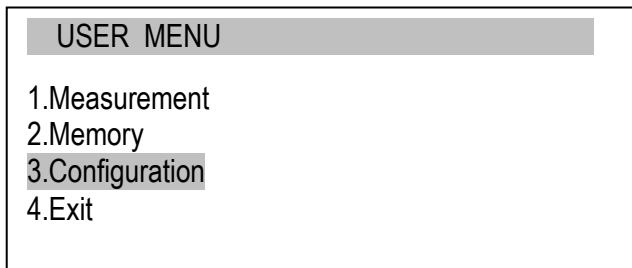

Use the navigation keys and *ENTER* to select *Keypad* and *Buzzer*, and one of the following options:

- *ON* – sound ON,
- *OFF* – sound OFF.

14.3.9 Automatic power OFF (Auto-OFF)

This option allows for an automatic cut-off of the gauge's power supply to save the battery's energy.

USER MENU
1.Measurement
2.Memory
3.Configuration
4.Exit

CONFIGURATION
1.Interface
2.Calibration
3.Info
4.Time&date
5.LCD settings
6.Language
7.Printout
8.Keyboard
9.Auto-OFF
10.Battery
11.External input
12.Firmware Update
13.Defaults
14 Exit

AUTO-OFF	
1. Status	OFF
2. Exit	

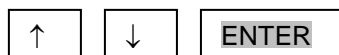

AUTO-OFF	
1. Status:	<OFF> <BAT> <ON>
2. Exit	

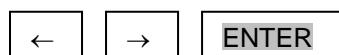

Use the navigation keys and *ENTER* to select *Auto-OFF* and *Status*, and one of the following options:

- *ON* – the power is turned off after 5 minutes, the indications remain unchanged,
- *BAT* – the power is turned off when the battery is low,
- *OFF* – the power is not turned off.

14.3.10 Monitoring the batteries' charge level (Battery)

This option is used for reading the charge level of the batteries and allows for the charging to be turned off to protect ordinary batteries, if such batteries are used instead of rechargeable batteries.

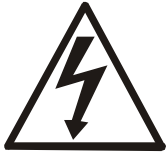

Charging ordinary batteries used instead of rechargeable batteries may lead to major damage to the gauge.

USER MENU
1.Measurement
2.Memory
3.Configuration
4.Exit

CONFIGURATION
1.Interface
2.Calibration
3.Info
4.Time&date
5.LCD settings
6.Language
7.Printout
8.Keyboard
9.Auto-OFF
10.Battery
11.External inout

BATTERY	
1. Charging	OFF
2. Level	80%
3. Exit	

↑	↓	ENTER
---	---	-------

BATTERY	
1. Charging	<OFF> <ON>
2. Level	80%
3. Exit	

←	→	ENTER
---	---	-------

Use the navigation keys and *ENTER* to select *Battery* and *Charging*, and one of the following options:

- *ON* – charging ON,
- *OFF* – charging OFF.

14.3.11 External input

This option can be used when force gauge is applied in any kind of automated process. THRESHOLD (optionally) output is used for this function so when using this option threshold function should be turned off.

USER MENU	
1.Measurement	
2.Memory	
3.Configuration	
4.Exit	

CONFIGURATION	
...	
8. Keyboard	
9. Auto-OFF	
10. Battery	
11. External input	

EXTERNAL INPUT	
1. Status :	<OFF><TRIGGER><GATE>
2. Exit	

Using navigation keys and *ENTER* key choose *Configuration* option and then *External input*. Choose *Status* option and using ← and → keys choose from:

- *OFF* – function off,

- *TRIGGER*:

a) manual measurement mode – measurement storing initiated by a single external signal,

b) automatic measurement mode – storing of set quantity of measurements initiated by a single external signal,

- *GATE*:

a) manual measurement mode - measurement storing initiated by a single external signal while *MEM* key is pressed,

b) automatic measurement mode – storing of set quantity of measurements initiated by external signal state time window.

14.3.12 Firmware update

Option designated for service

Option enables program update by connecting force gauge to computer using RS232 or USB interface. *Firmware update* message on force gauge's display is connected with this option. To delete this message, disconnect the force gauge from supply.

14.3.13 Defaults

This option restores factory settings (default settings) for all options.

The image shows a sequence of three menu screens. The first screen is titled 'USER MENU' and lists four options: 1.Measurement, 2.Memory, 3.Configuration, and 4.Exit. The second screen is titled 'CONFIGURATION' and lists options 7. Date and time, 8. Auto-OFF, 9. Battery, and 10. Defaults. The third screen is titled 'DEFAULTS' and asks 'Restore default settings?' with two options: NO and YES. Below the screens are three buttons: an up arrow, a down arrow, and an ENTER key.

USER MENU

- 1.Measurement
- 2.Memory
- 3.Configuration
- 4.Exit

CONFIGURATION

...

7. Date and time
8. Auto-OFF
9. Battery
10. Defaults

DEFAULTS

Restore default settings?

NO
YES

↑ ↓ ENTER

Use the navigation keys and *ENTER* to select *Reset settings* and the option *YES*.

As a result of restoring factory settings, the device will reset and start continuous measurement.

15. Maintenance, troubleshooting and repairing minor types of damage

1. Keep the gauge clean.
2. When using the force gauge, make sure that no contamination gets between the gauge plunger and the enclosure. Upon identifying any contamination, remove it using a tool which does not conduct electricity.
3. Unauthorised person may not perform any repairs.
4. Have the gauge repaired by your local servicing facility. A list of servicing facilities is enclosed in the warranty.

Messages and faults:

Message/fault	Cause	Recommendation
The message RESETTING is displayed for an extended period of time.	Resetting process disturbed	Keep the gauge in motionless position and press $\rightarrow T(0) \leftarrow$
Message: AD range exceeded (+/-)	Resetting process disturbed	Put the gauge in horizontal position and turn it off and on using the <i>ON/OFF</i> key.
The values indicated by the gauge diverge significantly from correct values	Gauge out of adjustment	Contact a servicing facility to calibrate the gauge
Units displayed are different from the selected units	<i>UNIT/CLEAR</i> key pressed by accident	Press the <i>UNIT/CLEAR</i> key several times to display the correct units

16. Force gauge menu diagram

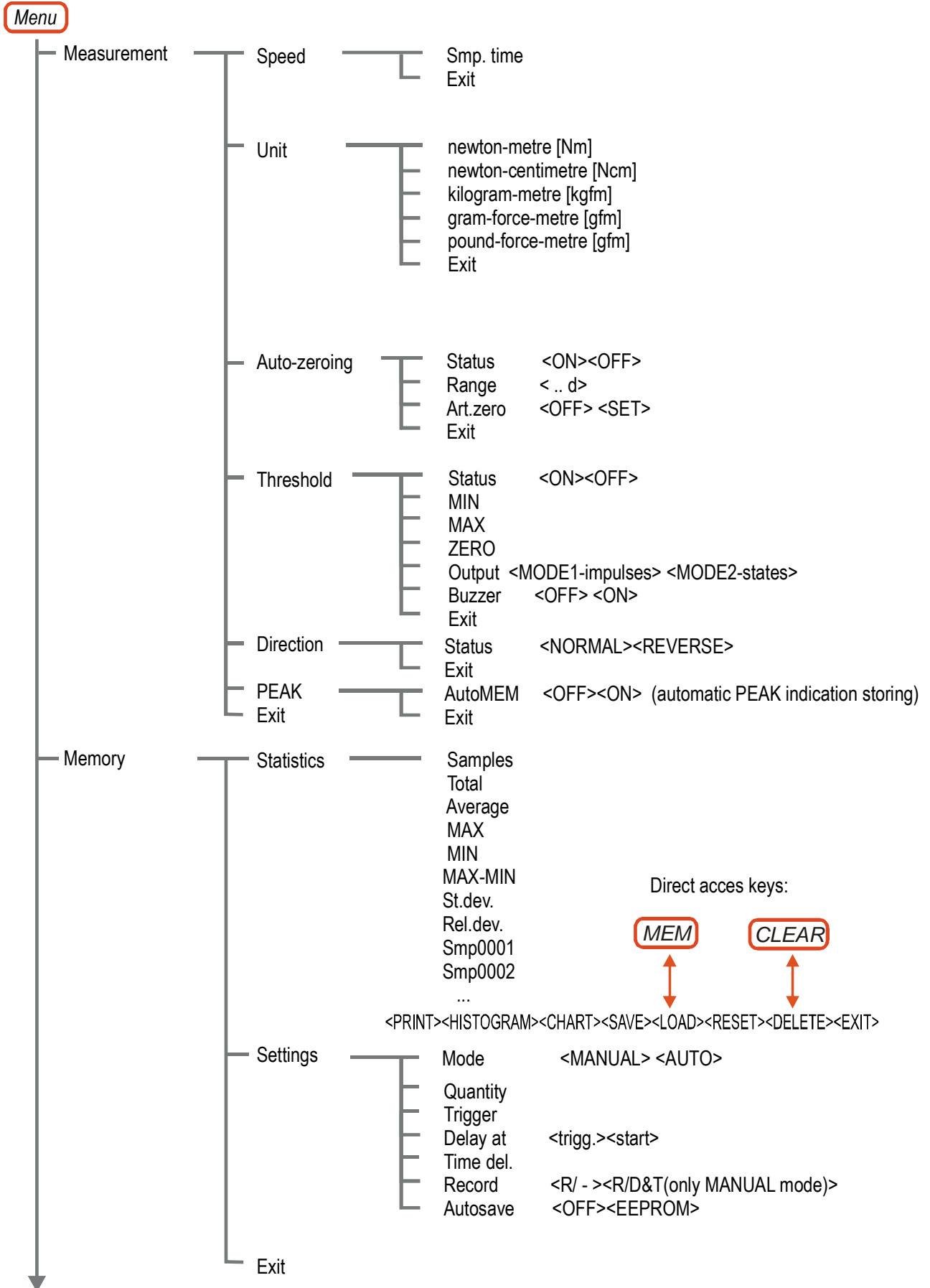

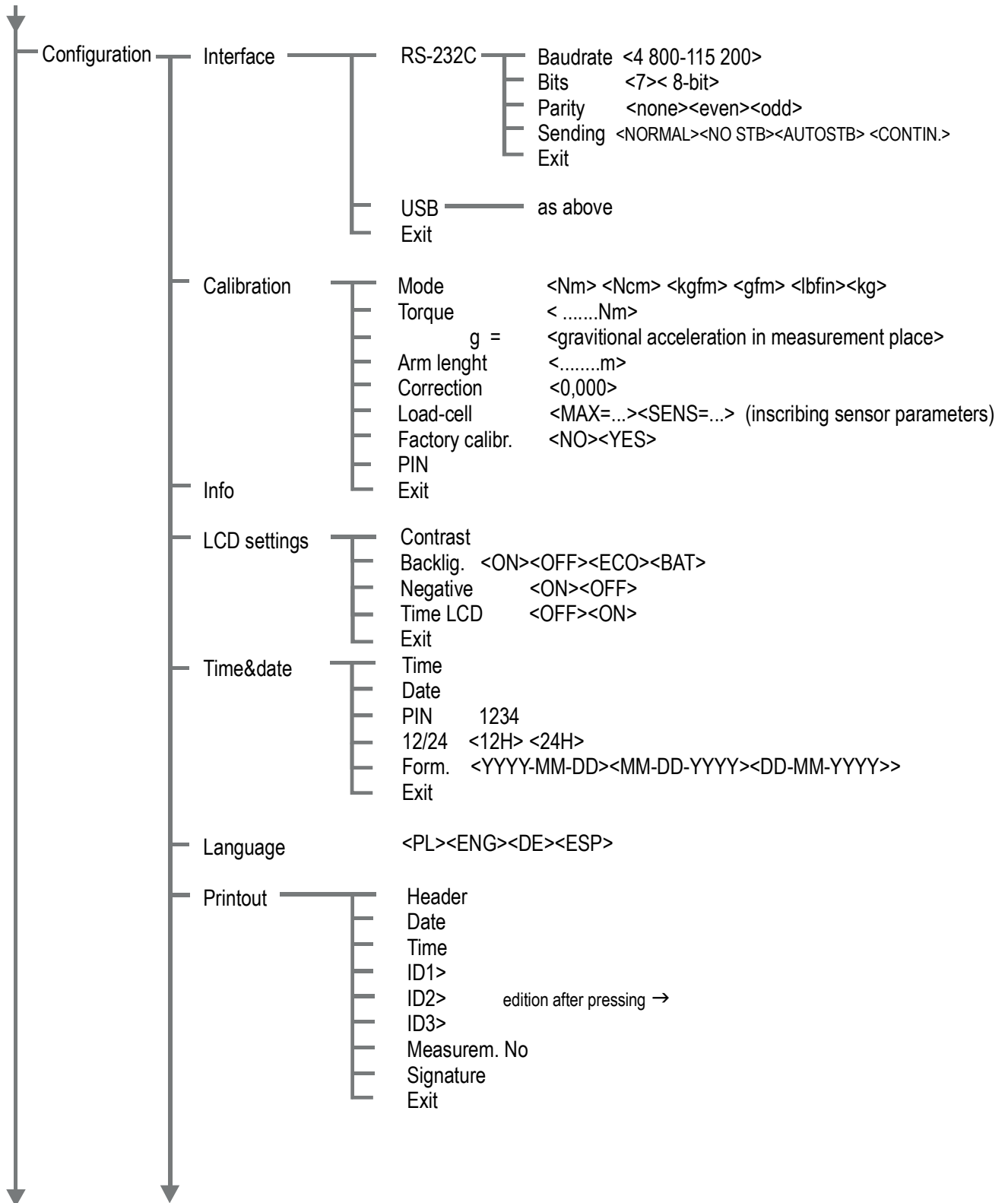

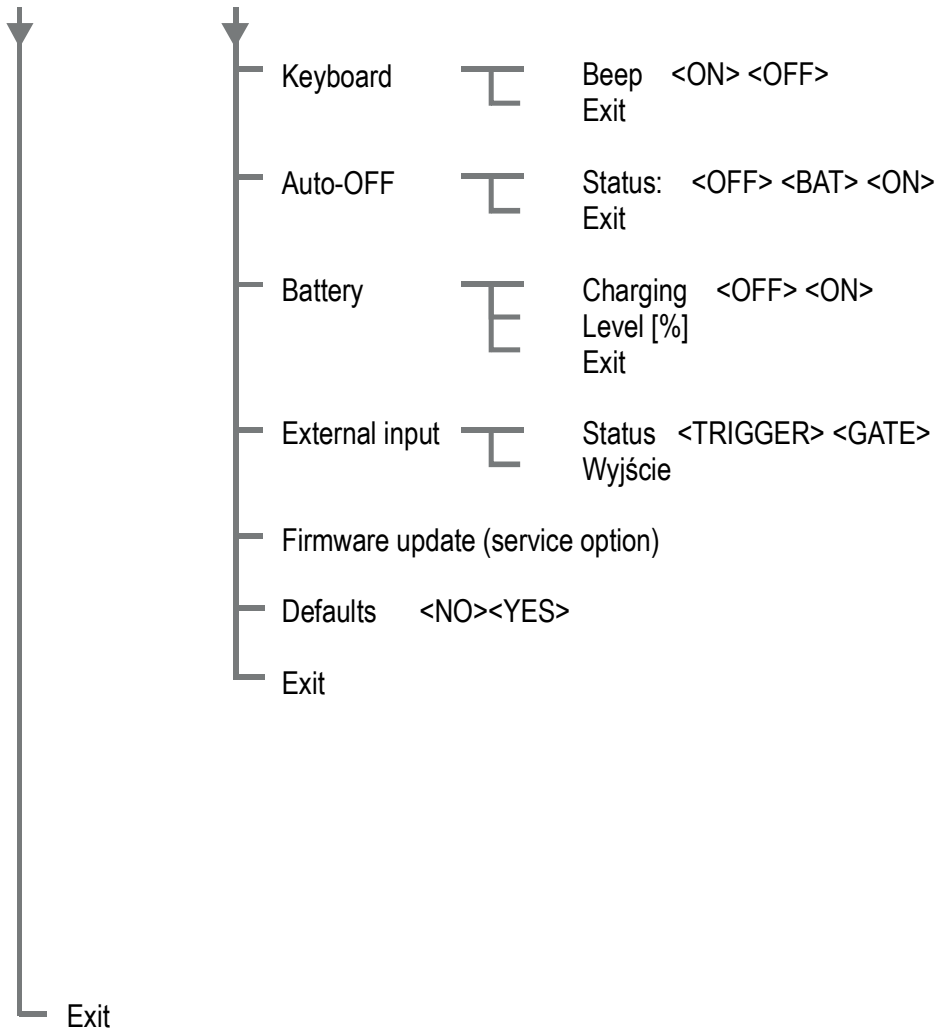

Declaration of Conformity

The last two digits of the year in which the CE marking was affixed: 16

We:



AXIS Spółka z o.o. 80-125 Gdańsk, ul.Kartuska 375B

confirm with all responsibility that force gauges:

FSA2, FSA5, FSA10

marked with CE mark comply with the following:

1. Directive 2004/108/EWG (electromagnetic compatibility) and harmonized norms:

- PN-EN 61000-4-3+A1:2008+A2:2011
- PN-EN 61000-6-3:2008+A1:2011
- PN-EN 55011:2007+A2:2007

Additional information:

- Conformity evaluation were carried out by Laboratorium Badawcze Oddziału Instytutu Elektrotechniki in Gdańsk, accredited by PCA (AB007), examination report nr 109/LMC-738/2009 from 28.09.2009 r.

Gdańsk, 30-10-2015 r.

Per pro Director of AXIS Sp. z o.o.:

Production Manager Jan Kończak

A handwritten signature in black ink, appearing to read 'Jan Kończak', is written over a horizontal line. Below the line, the word 'Signature' is printed in a serif font.

Notes